



Pall Microelectronics

Microza[®] UF Module
for
Ultrapure Water
OLT-6036/H

Operating Guidelines

Table of Contents

I.	General Description	1
II.	Module Specifications	2
III.	Inspection before shipment	3
IV.	Performance	4
4-1	Filtration pressure and flux rate	4
4-2	Feed flow rate and head loss	5
4-3	Resistivity rinse-up time at start-up	6
4-4	TOC rinse-up at start-up	7
V.	Recommended operating parameters	8
5-1	Operating parameters	8
5-2	General guidelines	8
VI.	Module installation	9
6-1	Mounting of module	9
6-2	Module rack assembly	9
VII.	Operating Procedure	11
7-1	Rinse-up	11
7-2	Setting of operating conditions	11
7-3	Shut down procedure	12
7-4	Hot water sanitization	13
7-5	General guidelines	15
7-6	Piping	16

Microza is a trademark of Asahi Chemical Industry Co. Ltd

I. General Description

OLT-6036 and OLT-6036H are outside-in type UF modules. They are up-graded versions of OLT-5026 and OLT-5026G with double the filtration capacity for reduced cost of operation.

Features of the OLT-6036/H

1. Higher filtration performance

A high module flow rate (16.5 m³/hr or 72 gpm) is achieved while maintaining a low molecular weight cut-off (MWCO) removal rating.

2. Membrane with low Molecular Weight Cut-off (MWCO)

With its 6,000 nominal MWCO rating, the OLT-6036 series modules can reject fine particles, endotoxins and large dissolved molecules.

3. Cleanliness

The OLT-6036/G modules use selected materials with very low extractables resulting in rapid resistivity, particle and TOC rinse up.

4. Hot water tolerance

OLT-6036/H modules are composed of materials having excellent heat resistance and very low extractables. The modules can tolerate hot water sanitization and the OLT-6036G is suited for continuous hot water service.

5. Sanitary construction

There are two permeate nozzles at both ends of module. This construction minimizes dead space to prevent recontamination of the UPW.

II. Module Specifications

2-1 Module specifications are shown in the table II-1.

2-2 OLT-6036/H modules are manufactured in a clean environment and have a preservative containing 65% glycerol, 2 % ethanol and 33% water.

		Units	OLT-6036	OLT-6036H High Pressure
Performance	MWCO	daltons	6000	6000
	Minimum permeate flow ¹	m ³	16.5	16.5
		gpm	72	72
Dimensions	Fiber inner/outer diameter	mm	0.6/1.0	0.6/1.0
	Membrane area	m ²	34	34
		ft ²	366	366
	Module length	mm	1177	1177
		in	46.3	46.3
Module diameter ²	mm	172	172	
	in	6.8	6.8	
Operating Conditions	Maximum inlet pressure (122°F/50°C) ³	bar	6	9
		psi	90	130
	Maximum differential transmembrane pressure (122°F/50°C) ³	bar	3	3
		psi	45	45
	Maximum temperature	°F/°C	194/90	194/90
	Maximum operating temperature ⁴	°F/°C	176/80	176/80
pH range		1-14	1-14	
Materials	Membrane	Polysulfone		
	Housing	Polysulfone		
	Membrane bundle sleeve	Polyethylene		
	Guard	Polysulfone		
	Potting material	Epoxy resin		
	Gasket	Viton		

¹ Initial clean water permeate flow at 77°F/25°C and 14.5 psi/1 bar average transmembrane pressure.

Design flow is 60-65 gpm.

² Nominal shell diameter excluding headers and permeate ports.

³ Pressure must be reduced at higher temperatures.

Consult operating manual.

⁴ For operating temperatures >176°F/80°C, please contact Pall Corporation.

III. Inspection prior to shipment

Modules are inspected and tested prior to shipment for:

- Molecular weight cut-off removal rating
- Filtration capacity test (flow rate per module)
- Dimensions
- Visual defects
- Membrane integrity (at ambient & 90° C water)
- Seal integrity (at ambient & 90° C water)
- Particle count in the permeate
- Permeate resistivity

IV. Performance

4-1 Filtration pressure and flux rate

An example of relationship between filtration pressure and flux rate is shown in the Fig. 4-1.

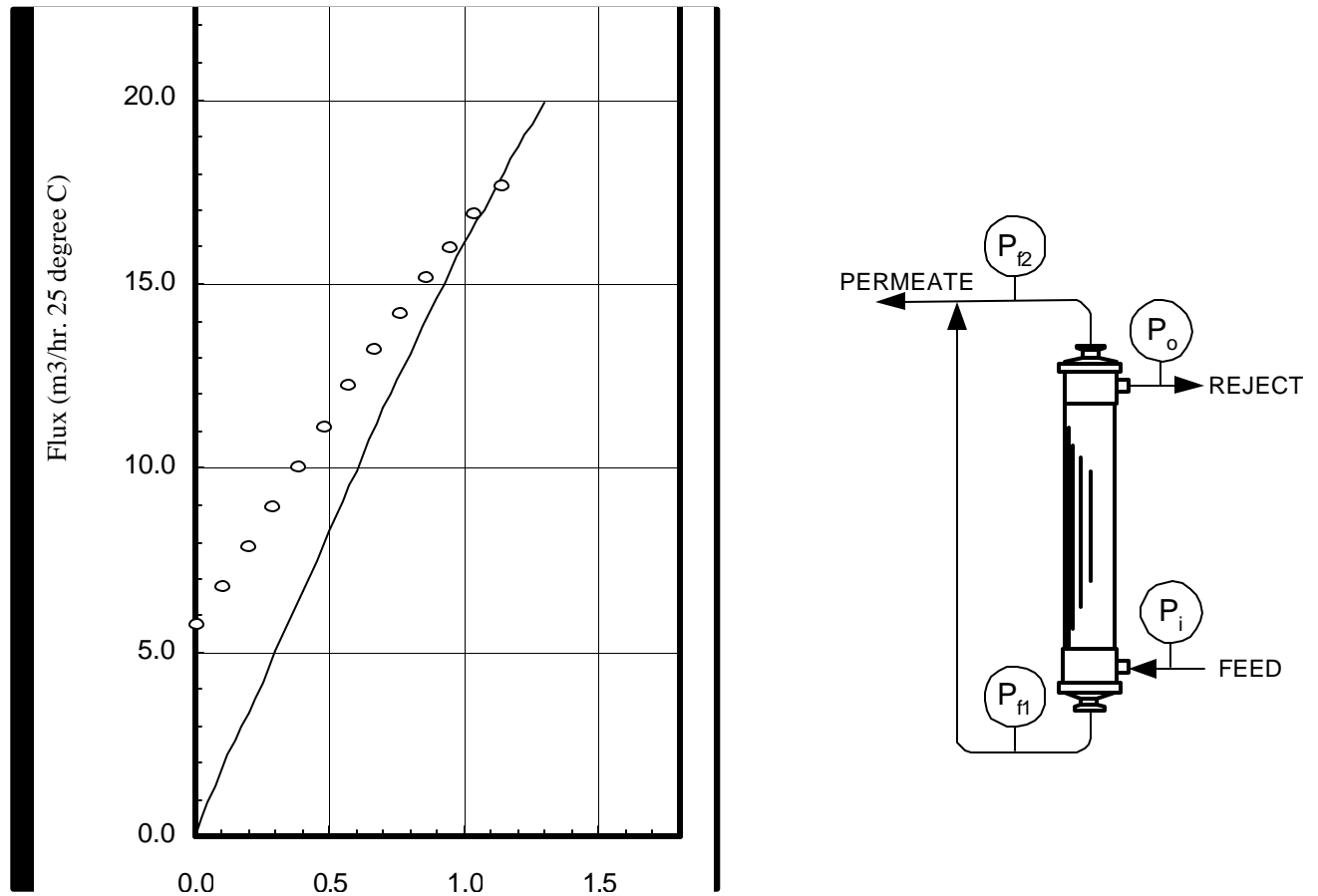

- (1) Filtration pressure = $(P_1+P_2)/2 - (P_{f1}+P_{f2})/2$
- (2) Feed water: Ultrapure water, number of particles > 0.1 μm is less than 50 per ml.
- (3) Recovery rate: 95%

Fig. 4-1 Filtration pressure vs. Flux rate

4-2 Feed flow rate and head loss

Fig. 4-2 shows an example of relationship between feed flow rate and head loss.

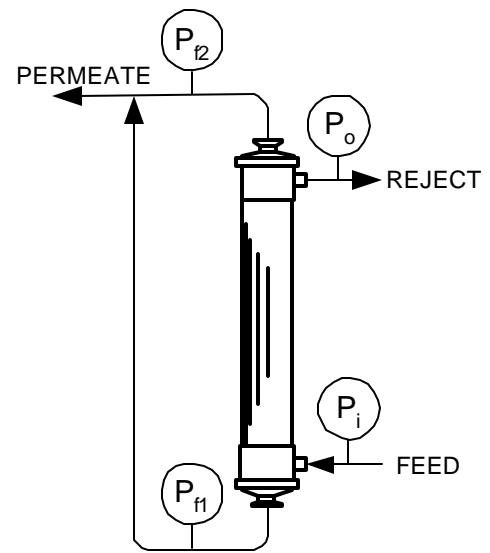
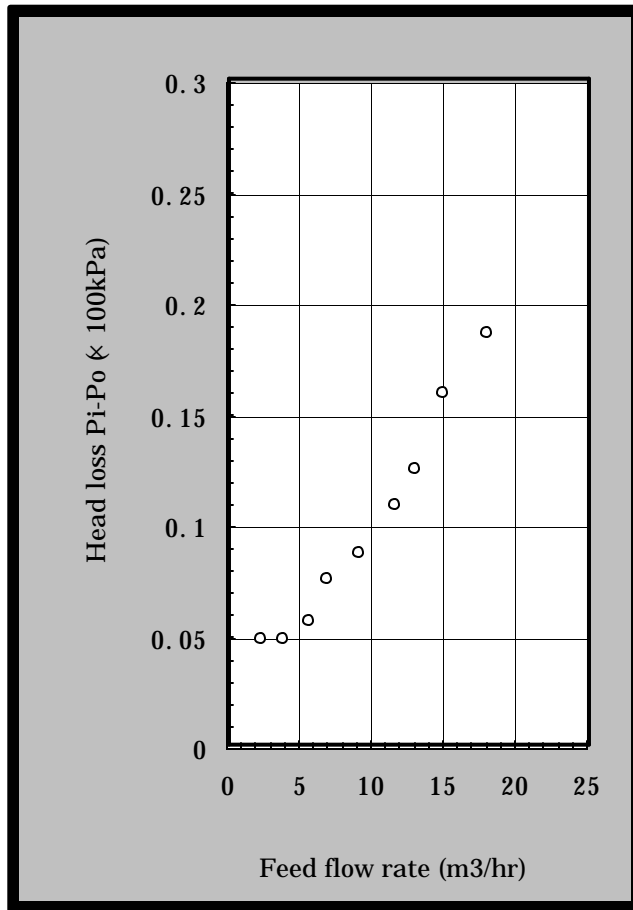

- (1) Module: Install vertically and feed water to bottom side port as shown in the diagram.
- (2) Feed water: Ultrapure water, number of particles $> 0.1 \mu\text{m}$ is less than 50 per ml.
- (3) Head loss: $P_i - P_o$ (kPa)
- (4) Recovery rate: permeate/feed is 95%.

Fig. 4-2 Feed flow rate vs. Head loss

4-3 Resistivity rinse-up time at start up

- (1) The UF module contains a preservative (65 % glycerol, 2 % ethanol and 33 % water). The modules should be rinsed with UPW ($> 18 \text{ M}\Omega\text{-cm}$) until the permeate resistivity reaches the desired level.
- (2) Fig. 4-3 shows an example of a resistivity rinse-up curve.
- (3) The rinse-up time is inversely proportional to the feed water flow rate.

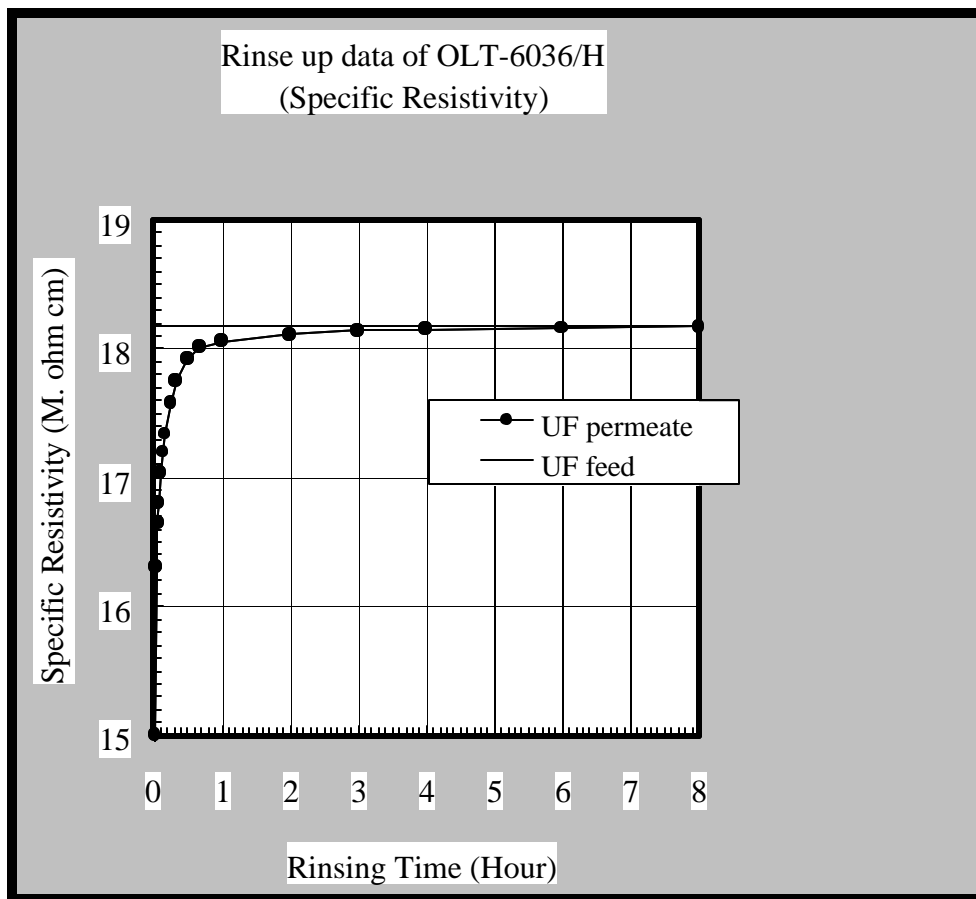

[Operating conditions]

- (1) Flux rate: $10.0 \text{ m}^3/\text{h}$ or 44 gpm
- (2) Recovery rate: 95 %
- (3) Resistivity of feed: $18.17 \text{ M}\Omega\text{-cm}$ at $25 \text{ }^\circ\text{C}$
- (4) Resistivity meter: DKK, AQ-11

Fig. 4-3 Resistivity rinse-up curve at start-up

4-4 TOC rinse-up at start up

- (1) The UF module contains a preservative (65 % glycerol, 2 % ethanol and 33 % water). The modules should be rinsed with UPW) until the permeate TOC reaches the desired level.
- (2) Fig. 4-4 shows an example of a TOC rinse-up curve.
- (3) The rinse-up time is inversely proportional to the feed water flow rate.

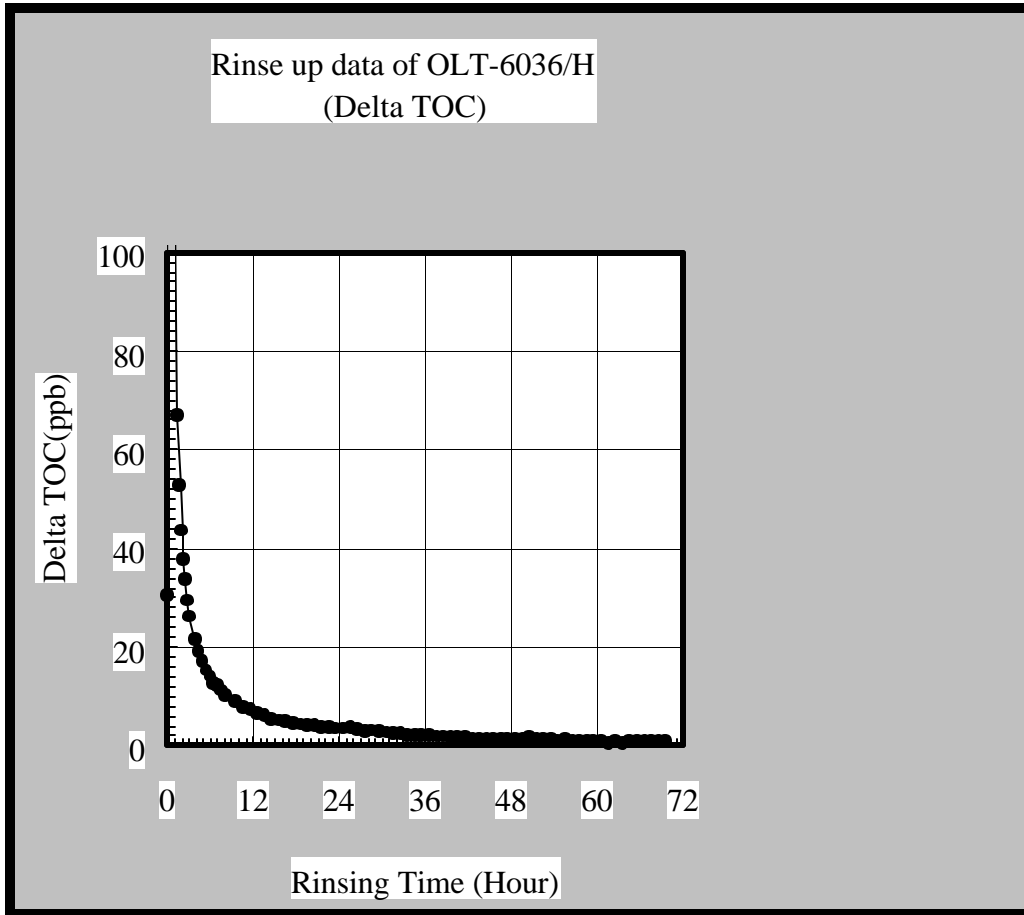

[Operating conditions]

- (1) Flux rate: 10.0 m³/h or 44 gpm
- (2) Recovery rate: 95 %
- (3) TOC of feed: 2 ppb
- (4) TOC meter: ANATEL

Fig. 4-4 Typical TOC rinse-up curve at start-up

V. Recommended operating parameters

5-1 Operating parameters

The following parameters should be considered in the design and operation of the UF system.

Filtration mode	Single filtration
Design flux rate	14 - 15 m ³ /hr or 55 – 60 gpm per module
Recovery rate	90 - 95 %
Filtration pressure	Start at 1 bar / 15 psi and increase as needed
Feed water conditions	(1) Particle count: >0.1 μm, <100 particles/ml (2) Bacteria: <0.1 CFU/ml TOC < 10 ppb
Hot water sanitization	(1) 90 °C hot water, 1 hr. (2) Recovery rate < 90 % (3) Flux rate less than 10 m ³ /h / 44 gpm
Flushing	Do not operate with the permeate ports closed. Fibers may become damaged.

5-2 General guidelines

- UF reject can be returned upstream of the RO unit.
- Upstream degasification is recommended since dissolved gas in the feed water to the UF module may be adsorbed by the membrane resulting in reduced performance.

VI. Module Installation

6-1 Mounting of module

- (1) The weight of a 6036 module filled with water is 32 kg (70 lb.). This necessitates that the modules not be supported by the piping alone, as the stress on the module's connections would be excessive. The module weight must therefore be supported independently, and this is best accomplished by having the module rest on the module skid frame such that it is supported on the flat portion of the module's lower End Cap – as illustrated in the Typical Installation drawing. Supporting the module by clamping the module body with U-bolts to system framing may severely, and irreversibly, damage the module – cause it to crack. However, loose guiding/stabilizing of the module body is acceptable, and must be designed to allow for the module's thermal expansion during sanitization.
- (2) The modules must be installed vertically, with the 'feed' water entering the lower side port (Feed port) and with the 'reject' exiting from the upper side port (Reject port). The Feed and reject port connections are identical (Please refer to the Module Assembly drawing in the Appendix).

6-2 Module rack assembly

Permeate is collected from both ends of the module to ensure that there are no stagnant areas within the membranes. Refer to the Typical Installation drawing with attendant instructions for recommended module piping arrangement. Also ensure that the permeate manifold is elevated above the modules to ensure complete air evacuation which will avoid any stagnant (dead) areas that could harbor bacterial growth and that may not be able to be adequately cleaned/sanitized.

KEY DESIGN CONSIDERATIONS NOTED ARE:

- PIPING CONNECTIONS TO THE MODULES DESIGNED TO ACCOMMODATE DIFFERENTIAL THERMAL EXPANSIONS WITHOUT PLACING STRESS ON THE MODULE CONNECTIONS.
- FOR 5" & 6" (OT-50 & OT-60) MODULES THE MECHANICAL SUPPORT IS VIA THE LOWER MODULE END CAP; I.E., SUPPORTING THE MODULE WEIGHT BY THE MODULE — NOT BY THE SYSTEM PIPING. DO NOT SUPPORT THE MODULES BY CLAMPING THE MODULE PIPE TO SYSTEM FRAMING — LOOSE GUIDING/STABILIZING ONLY OF THE MODULE IS ACCEPTABLE. MAX THICKNESS OF FRAME SUPPORT IS 1/4" TO CLEAR TRI-CLAMP HANDLE.
- ENSURE THAT THE MODULE IS ORIENTED/INSTALLED WITH THE FEED INLET ON THE BOTTOM AND THE CONCENTRATE (REJECT) OUTLET ON THE TOP. NOTE THE FEED AND CONCENTRATE LABELS ATTACHED TO THE MODULE AT THESE CONNECTION PORTS.
- EXTRACT PERMEATE FROM BOTH THE UPPER AND LOWER MODULE PERMEATE CONNECTIONS. THIS WILL AVOID STAGNANT AREAS.
- ENSURE THAT THE PROPER PERMEATE PORT CONNECTION TRI-CLAMP CLAMPS ARE USED WITH THE SPECIFIC TRI-CLAMP TO PIPE ADAPTER USED; E.G., A GEORGE FISHER PVDF ADAPTER REQUIRES THEIR UNDER SPECIAL CLAMP. ALSO ENSURE THAT THE CLAMP IS OF A FLEXIBLE DESIGN SUITABLE FOR CONNECTING PLASTIC FLANGES. THE CLAMP SUPPLIED BY PALL IS SUITABLE TO CONNECTING TO ADAPTERS WITH STANDARD TRI-CLAMP FLANGE DIMENSIONS.
- ARRANGE THE MODULE PIPING TO BE INBOARD OF THE PROCESS PIPING TO FACILITATE ACCESS FOR MODULE EXCHANGE.

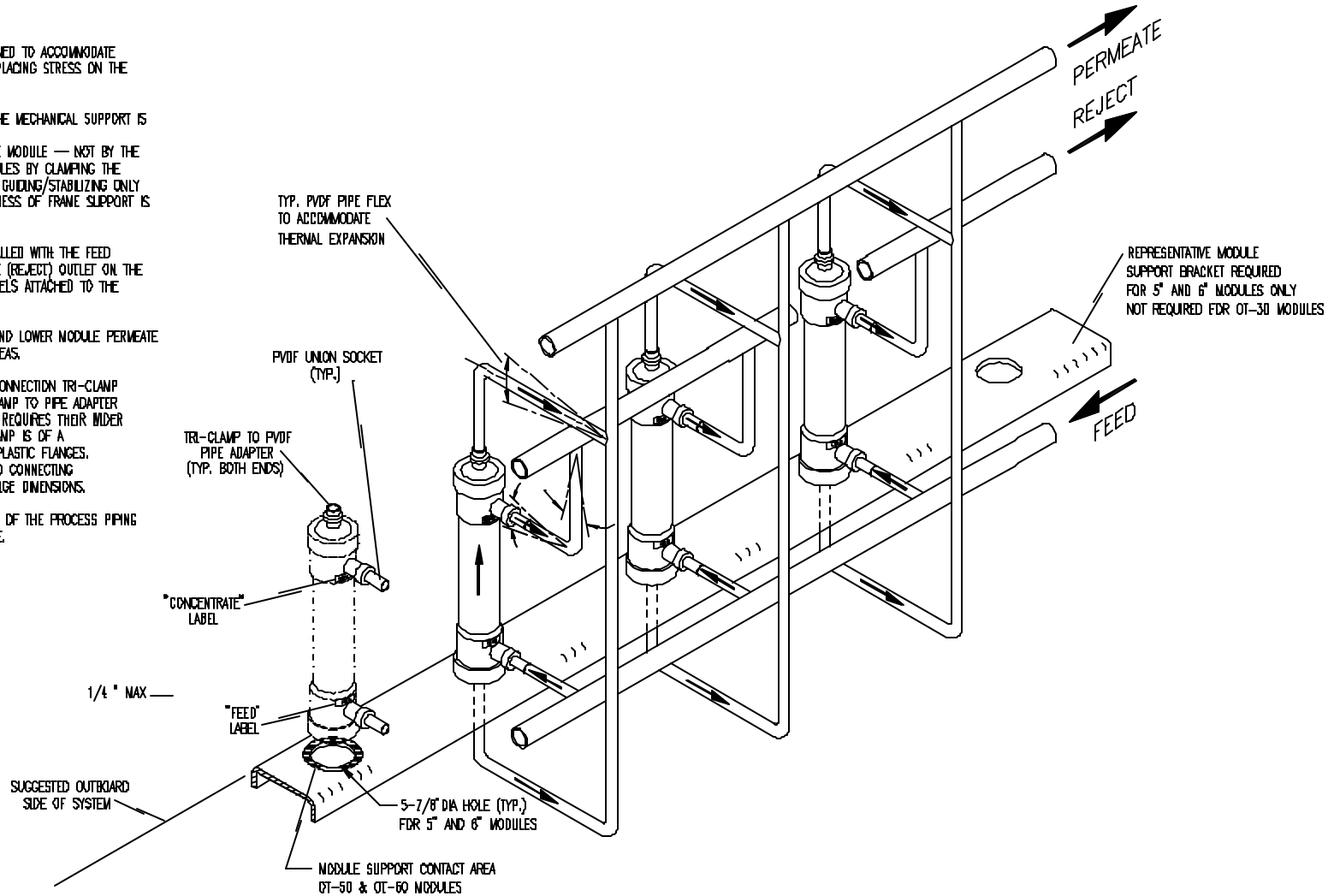

TYPICAL INSTALLATION

for

OT-30, OT-50 & OT-60 MICROZA MODULES



VII. Operating Procedure

7-1 Rinse-up

- (1) The module contains a preservative comprising 65% glycerol and 2% ethanol. It must be rinsed with UPW until the required TOC and resistivity levels in the permeate are achieved.
- (2) Care must be taken to avoid contaminating the permeate side of the module during installation.
- (3) Typical rinse-up curves are shown in Fig. 4-3 and 4-4.

7-2 Setting of operating conditions

7-2-1 Filtration mode

- (1) Outside-in filtration mode
- (2) Single pass filtration is recommended.

7-2-2 Filtration pressure

- (1) Filtration pressure is defined by the following formula.

$$(P_i+P_o)/2 - (P_{f1}+P_{f2})/2$$

Where: P_i is module inlet pressure

P_o is module outlet (reject) pressure

P_{f1} is permeate side pressure 1 (bottom).

P_{f2} is permeate side pressure 2 (top).

Maximum transmembrane pressure $(P_i+P_o)/2 - (P_{f1}+P_{f2})/2$ is 3 bar / 45 psi at 25 °C.

- (2) Maximum allowable feed pressure of module at 25 °C:

OLT-6036 6 bar or 90 psi

OLT-6036H 9 bar or 130 psi

- (3) Typical design flux rates for UPW service are 12.5- 13.5 m³/h or 55 – 60 gpm. Design rates will vary depending on feed water quality.

7-2-3 Recovery rate

- (1) Generally speaking, 90-95 % of feed is recovered as permeate.
- (2) The remaining 5-10 % is rejected from the UPW system.
- (3) 100% recovery (dead end filtration) results in the accumulation of particles and bacteria on the membrane surface. This may result in a decrease in membrane performance.

7-2-4 Maximum flux rate

Exceeding the maximum flux rate, 20 m³/h or 90 gpm, may damage UF hollow fiber membranes.

7-2-5 Operating pressure vs water temperature

The allowable operating pressure will vary with water temperature. See tables below.

OLT-6036

UF feed temperature (°C)	Max. transmembrane pressure	Max. feed pressure	Max. permeate pressure
<30	3 bar / 45 psi	6 bar / 90 psi	6 bar / 90 psi
30 - 50	3 bar / 45 psi	5 bar / 75 psi	5 bar / 75 psi
50 - 70	2 bar / 30 psi	4 bar / 60 psi	4 bar / 60 psi
70 - 80	1.5 bar / 22 psi	3.5 bar / 50 psi	3.5 bar / 50 psi
80 - 90	1 bar / 15 psi	3 bar / 45 psi	3 bar / 45 psi

OLT-6036H

UF feed Temperature (°C)	Max. transmembrane pressure	Max. feed pressure	Max. permeate pressure
<30	3 bar / 45 psi	9 bar / 130 psi	9 bar / 130 psi
30 - 50	3 bar / 45 psi	8 bar / 120 psi	8 bar / 120 psi
50 - 70	2 bar / 30 psi	7 bar / 105 psi	7 bar / 105 psi
70 - 80	1.5 bar / 22 psi	6 bar / 90 psi	6 bar / 90 psi
80 - 90	1 bar / 15 psi	5 bar / 75 psi	5 bar / 75 psi

Design flow rate for hot water is typically 12.5- 13.5 m³/h or 55 – 60 gpm .
Do not exceed maximum flux rate of 20 m³/h or 90 gpm or maximum pressure at temperature.

7-2-6 Flushing

Never operate the module with the permeate ports closed.

7-3 Shut down procedure

- (1) Always maintain positive pressure within the UF modules.
- (2) Close the permeate valves before closing the module inlet valve
- (3) Pressure in the module should not exceed maximum values given in the tables above
- (4) Sanitize the modules prior to start up.

7-4 Hot water sanitization

7-4-1 Flow diagram for hot water sanitization

Two options are described below:

(1) Option No. 1

Hot water, supplied from a separate hot water tank, is fed to the upstream side of UF System. After passing through the UF modules, the hot water can either be used to sanitize downstream point-of-use piping or may be returned directly to the hot water tank. The dotted line delineates the flow path of the hot water.

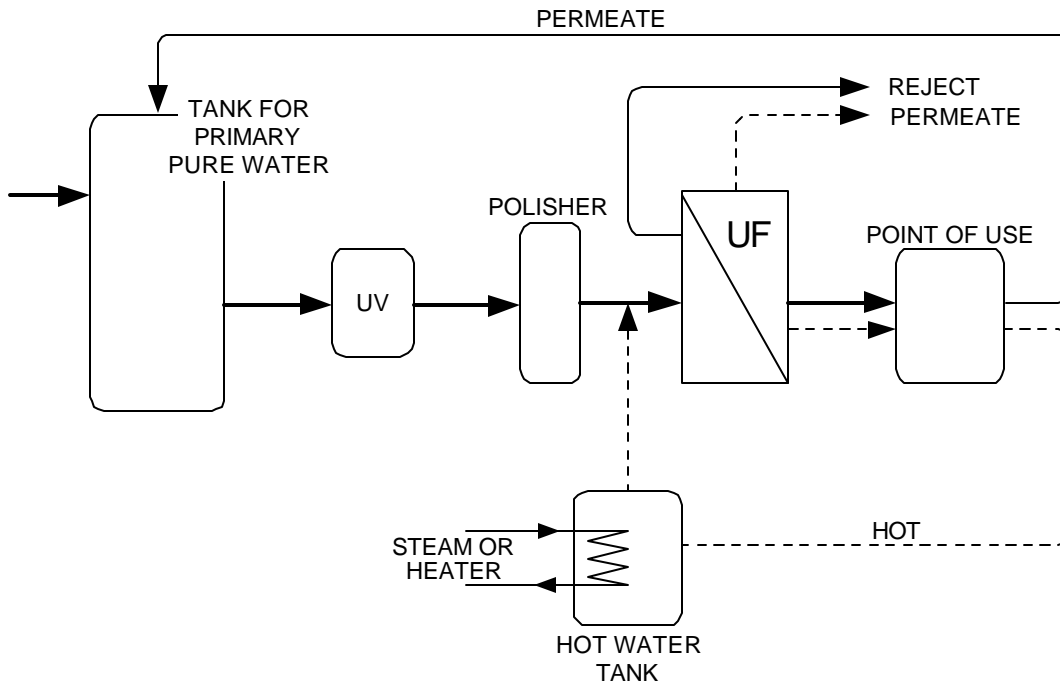

The water may be heated by either of two methods:

Method No. 1

Slowly increase the temperature of the water to 90 °C over a period of at least 15 minutes. Sudden changes in temperature should also be avoided during the cool down phase which should take about 15 minutes.

Method No. 2

If it is difficult to raise the temperature slowly, it may be increased in two stages. First feed 50° – 60° C to the UF system, recirculating for a minimum of 10 minutes. Then increase the water temperature in the tank to 90° C while continuing to feed the water to the UF system. To cool the system, perform the procedure in reverse.

(2) Option No. 2

A heat exchanger, installed in the UPW feed line, supplies hot water to the UF system, as well as to downstream piping, if desired. The dotted line delineates the flow path of the hot water.

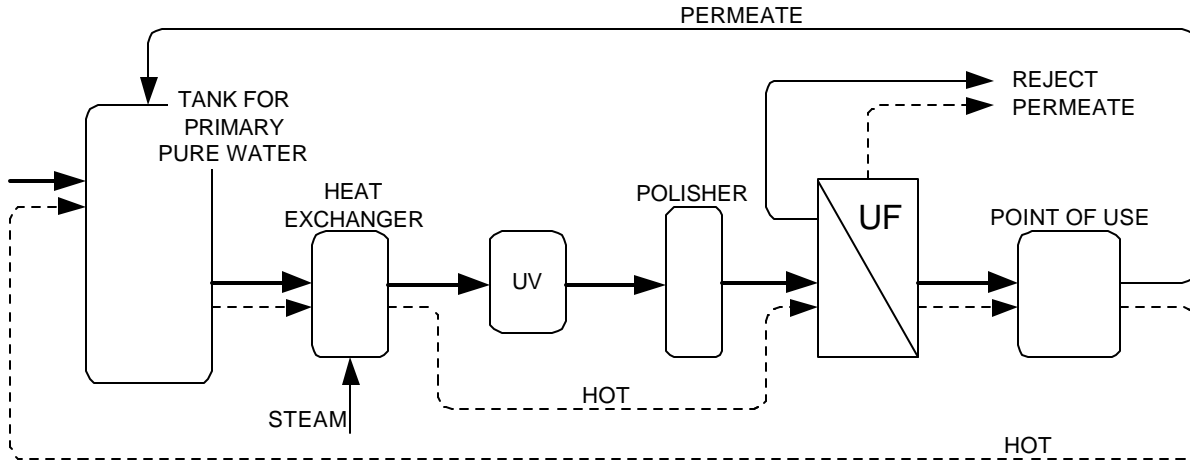

Refer to Method No. 1 on page 15 for heating the water.

7-4-2 General guidelines for hot water sanitization

Sanitization

Temperature:	90° C
Minimum Flux:	3 – 4 m ³ /h or 13 - 17 gpm
Time:	minimum 1 hour
Reject:	5 % (discharged to drain)

NOTE: BACK PRESSURE WILL PROBABLY BE REQUIRED ON THE PERMEATE SIDE IN ORDER TO OBTAIN THE MINIMUM FLUX PER MODULE.

Flushing

Temperature:	ambient
Reject:	5 %
Flux:	minimum 9 m ³ /h or 40 gpm
Time:	typically 30 - 60 minutes (the higher the flux, the shorter the time)

During sanitization, it is very important to keep the temperature throughout the system at 90° C. The minimum flux of 3 m³/h or 13 gpm may have to be increased if the temperature of the entire system cannot be maintained at 90 +/- 2° C due to heat loss.

During sanitization, the reject (concentrate) from the UF modules contains high levels of particles which have been cleaned off the membrane surface by the hot water. Therefore, the reject should be discharged at a rate of 160 liters/h or 0.7 gpm per module.

Do not drain out hot water from modules while they are still hot or warm. Hot membrane dries and loses its filtration capacity as soon it contacts air.

7-5 General guidelines

7-5-1 During storage and operation

- (1) Do not expose the module to direct sunlight or UV light. The module housing may be affected by UV light.
- (2) Do not expose the module to aromatic or chlorinated solvents as this may cause cracks in the housing.
- (3) To clean the module housing use water and wipe with a dry cloth.
- (4) Do not put any tape on the module housing
- (5) Do not write on the housing with a felt pen
- (6) Always keep water in the modules to prevent the UF membranes from drying out as this can result in a loss of filtration capacity.
- (7) Do not expose the modules to temperatures below freezing.
- (8) Protect the modules from impact and shock such as water hammer
- (9) Observe the feed and reject labels on the side ports during installation

7-5-2 In service

- (1) Introduce the feed water slowly. Adjust the flow to 2 m³/h or 9 gpm per module, increasing it only after the air in the module is completely vented. An initial high flow rate air with remaining in the module may cause the hollow fibers to vibrate resulting in membrane damage.
- (2) Do not flush the module with the permeate ports closed.
- (3) Do not exceed the maximum flow rate of 20 m³/h or 90 gpm per module.
- (4) Do not operate with the reject valve closed as this may result in rapid membrane fouling.

7-5-2.1 During hot water sanitization

- (1) Observe guidelines in section 7-4 to avoid thermal shock. Thermal shock may shorten expected module life.
- (2) Modules and piping are hot during sanitization. Since hot water may leak or drip from modules or piping check for leaks from all sealing points prior to starting the sanitization procedure.
- (3) Protect personnel from exposure to hot water
- (4) Do not touch modules or non-insulated pipes during hot water sanitization

7-5-3 General

- (1) Protect the permeate side of the module from contamination during installation.
- (2) Contact Pall Corporation for hydrogen peroxide sanitization guidelines. Chemical sanitization is performed at ambient temperature using 1 - 3% H₂O₂.

7-6 Piping

7-6-1 Thermal expansion of module

The module expands about 4 mm in length as the temperature increases from 20 °C to 90 °C. The linear expansion coefficient of the material is $5.510^{-5}/^{\circ}\text{C}$. This should be taken into account when designing the module support rack.

7-5-4 Module installation

- (1) Both permeate ports must be connected and operational. Permeate piping should not have any air pockets.
- (2) Modules should be installed vertically with the side feed port at the bottom and the reject side port at the top.
- (3) Take into account piping, gravity and thermal stresses on the module during the design phase.
- (4) Dummy modules should only be used for fit up. They should not be used for flushing.