

Thermo Scientific NESLAB System II Heat Exchanger

Thermo Scientific Manual P/N 002179 Rev. 04/17/07

Installation Operation Basic Maintenance

Visit our Web site at:

<http://www.thermofisher.com/tc>

Product Service Information, Applications
Notes, MSDS Forms, e-mail.

Voice Info: (800) 258-0830



Thermo Fisher Scientific

25 Nimble Hill Road
Newington, NH 03801
Tel : (800) 258-0830 or
(603) 436-9444
Fax : (603) 436-8411
www.thermofisher.com/tc

Sales, Service, and Customer Support

25 Nimble Hill Road
Newington, NH 03801
Tel: (800) 258-0830
Sales: 8:00 am to 5:00 pm
Service and Support: 8:00 am to 6:00 pm
Monday through Friday (Eastern Time)
Fax: (603) 436-8411
service.tc.us@thermofisher.com

Dieselstrasse 4
D-76227 Karlsruhe, Germany
Tel : +49 (0) 721 4094 444
Fax : +49 (0) 721 4094 300
info.tc.de@thermofisher.com

Building 6, No. 27
Xin Jinqiao Rd., Shanghai 201206
Tel : +86(21) 68654588
Fax : +86(21) 64457830
info.china@thermofisher.com

Statement of Copyright

Copyright © 2007 Thermo Fisher Scientific. All rights reserved.

This manual is copyrighted by Thermo Fisher Scientific.

Users are forbidden to reproduce, republish, redistribute, or resell any materials from this manual in either machine-readable form or any other form.

Table of Contents

PREFACE	
	Compliance 3
	WEEE/RoHS 3
	After-sale Support 4
	Warranty 4
	Unpacking 4
	Out of Box Failure 4
	Feedback 4
SECTION I	
Safety	
	Warnings 5
SECTION II	
General Information	
	Description 6
	Specifications 6
SECTION III	
Installation	
	Site 8
	Facility Water Requirements 8
	Electrical Requirements 9
	Plumbing Requirements 9
	Fluids 10
	Filling Requirements 10
	Water Quality Standards and Recommendations 11
SECTION IV	
Operation	
	Start Up 12
	Temperature Adjustment 12
SECTION V	
Special Features	
	Low Fluid Level Monitor 13
	High Temperature Monitor 13
	INTERLOCK Contacts 13
	Pressure Relief Valve 14
SECTION VI	
Maintenance	
	Service Contracts 15
	Cleaning 15
	Algae 15
	Pump Strainer 15
	Facility Water Strainer 16
	Flow Diagrams 17
SECTION VII	
Troubleshooting	
	Checklist 18
	Service Assistance 19
Warranty	

System II Quick Reference Operating Procedures

Installation

The unit has a heat exchanger, recirculation pump, stainless steel reservoir and a temperature controller. The unit should be located in an area with easy access to a cooling water source and a drain.

Cooling capacity is based the temperature of the cooling water supply and the cooling fluid supplied to your application.

Make sure the voltage of the power source meets the specified voltage, $\pm 10\%$.

The plumbing connections are located on the rear of the unit and are labelled COOLING WATER and PROCESS WATER. The COOLING WATER connections are $\frac{1}{2}$ inch FPT. The PROCESS WATER connections are $\frac{3}{4}$ inch MPT. Connect the COOLING WATER connections to the cooling water supply. Connect the PROCESS WATER connections to your application.

To fill the reservoir remove the reservoir access cover and fill the reservoir with clean cooling fluid to within 1 inch of the top.

Thermo Fisher recommends using distilled/deionized water with a 0.05 to 0.1 megohm-cm reading.

If you do not have access to distilled/deionized water we recommend using filtered tap water.

Operation

Before starting the unit, double check all electrical and plumbing connections. Make sure the circulating system has been filled with cooling fluid.

Ensure that the facility water is turned on.

To start the unit, place the OFF/ON/START Switch to the START position. The recirculation pump starts and the POWER ON lamp illuminates.

The TEMPERATURE gauge on the front of the unit indicates the temperature of the fluid in the reservoir. The temperature of the cooling fluid is adjusted by turning the recessed valve screw located on top of the unit.

Periodic Maintenance

Periodically inspect the reservoir fluid. If cleaning is necessary, flush the reservoir with a cleaning fluid compatible with the circulating system and the cooling fluid.

Units are equipped with pump strainers. If debris is in the system, the strainer will prevent the material from being drawn into the pump and damaging the pump vanes.

After initial installation, the strainer may become clogged. The strainer must be cleaned after the first week of installation. After this first cleaning, a monthly visual inspection is recommended. After several months, the frequency of cleaning will be established.

Before cleaning, disconnect the power cord from the power source and drain the reservoir.

Preface

Compliance

Products tested and found to be in compliance with the requirements defined in the EMC standards defined by 89/336/EEC as well as Low Voltage Directive (LVD) 73/23/EEC can be identified by the CE Mark on the rear of the unit. The testing has demonstrated compliance with the following directives:

LVD, 73/23/EEC Complies with IEC/EN61010-1

EMC, 89/336/EEC IEC/EN61326-1

For any additional information, refer to the Declaration of Conformity that shipped with the unit.

WEEE/RoHS

This product is required to comply with the European Union's Waste Electrical & Electronic Equipment (WEEE) Directive 2002/96/EC. It is marked with the following symbol:



Thermo Fisher Scientific has contracted with one or more recycling/disposal companies in each EU Member State, and this product should be disposed of or recycled through them. Further information on Thermo Fisher Scientific's compliance with these Directives, the recyclers in your country, and information on Thermo Scientific products which may assist the detection of substances subject to the RoHS Directive are available at:

www.thermo.com/WEEERoHS

After-sale Support

Thermo Fisher Scientific is committed to customer service both during and after the sale. If you have questions concerning the operation of your unit, contact our Sales Department. If your unit fails to operate properly, or if you have questions concerning spare parts, contact our Customer Service Department. Before calling, *please* obtain the following information:

- *BOM number*
- *Serial number*
- *Software version*

The BOM and serial number are on a label on the rear of the unit.

Unpacking

Retain all cartons and packing material until the unit is operated and found to be in good condition. If the unit shows external or internal damage contact the transportation company and file a damage claim. Under ICC regulations, this is your responsibility.

Out of Box Failure

An Out of Box Failure is defined as any product that fails to operate in conformance with sellers published specifications at initial power up. The unit must be installed in accordance with manufacturer's recommended operating conditions within 30 days of shipment from the seller.

Any Temperature Control product meeting the definition of an Out of Box Failure must be packed and shipped back in the original packaging to Thermo Fisher Scientific for replacement with a new unit; Seller to pay the cost of shipping. Customer must receive a Return Material Authorization (RMA) from Thermo Fisher prior to shipping the unit.

Warranty

Units have a warranty against defective parts and workmanship for one full year from date of shipment. See back page for more details.

Feedback

We appreciate any feedback you can give us on this manual. Please e-mail us at neslabmanuals@thermofisher.com. Be sure to include the manual part number and the revision date listed on the front cover.

Section I Safety

Warnings

Make sure you read and understand all instructions and safety precautions listed in this manual before installing or operating your unit. If you have any questions concerning the operation of your unit or the information in this manual, contact our Sales Department (see After-sale Support).

Performance of installation, operation, or maintenance procedures other than those described in this manual may result in a hazardous situation and may void the manufacturer's warranty.

Observe all warning labels.

Never remove warning labels.

Never operate damaged or leaking equipment.

Never operate the unit without cooling fluid in the reservoir.

Always turn off the unit and disconnect the line cord from the power source before performing any service or maintenance procedures, or before moving the unit.

Always empty the reservoir before moving the unit.

Never operate equipment with damaged line cords.

Refer service and repairs to a qualified technician.



In addition to the safety warnings listed above, warnings are posted throughout the manual. These warnings are designated by an exclamation mark inside an equilateral triangle with text highlighted in bold print. Read and follow these important instructions. Failure to observe these instructions can result in permanent damage to the unit, significant property damage, or personal injury or death.

Section II General Information

Description

The NESLAB System II Liquid to Liquid Heat Exchanger uses building recirculating or tap water as the secondary cooling medium to remove heat from the cooling fluid in the closed circulation loop.

The unit consists of a heat exchanger, recirculation pump, stainless steel reservoir, and a temperature controller.

The System II is available with two different plumbing configurations: single circulation loop, and dual circulation loop.

The single circulation loop unit has either two positive displacement pumps (PD-2) or an optional single turbine pump (TU-3), plumbed to a single inlet and outlet. The front panel switches and gauges correspond to this loop.

The dual circulation loop unit has two positive displacement pumps (PD-2), each plumbed to a separate inlet and outlet (A and B). The front panel switches and gauges labelled A, correspond with loop A. Front panel switches and gauges labelled B, correspond with loop B.

Specifications

Temperature Range

+10°C to +30°C

Temperature Stability¹

±1.0°C

Cooling Capacity^{1,2}

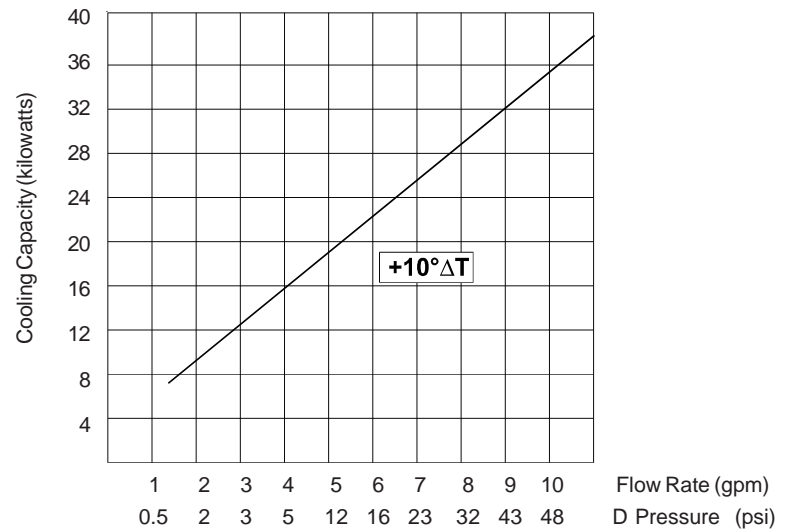

1. Specifications listed are for a standard unit, +20°C fluid temperature, with tap water as the cooling fluid.
2. Cooling capacity is based on a 10°C difference between the temperature of the cooling water supply (house water) and the cooling fluid supplied to the instrument being cooled (see Section III, Facility Water Requirements). Pressure differential is required from house water.

PD 2 Pumping Capacity¹
(Standard Configuration)

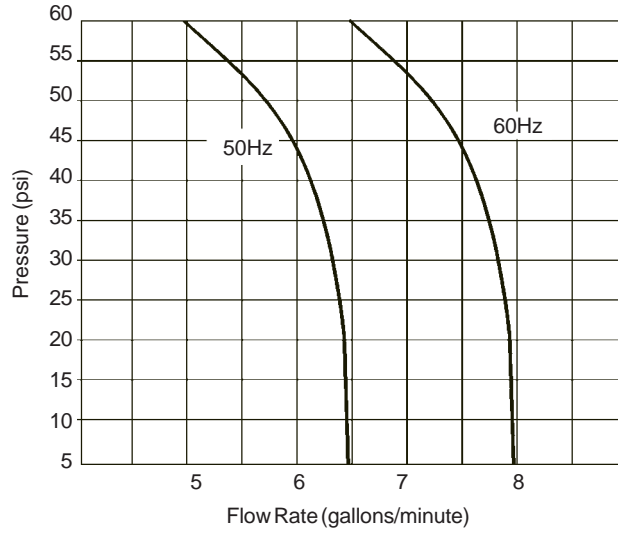

TU 3 Pump Capacity
(Optional Configuration)

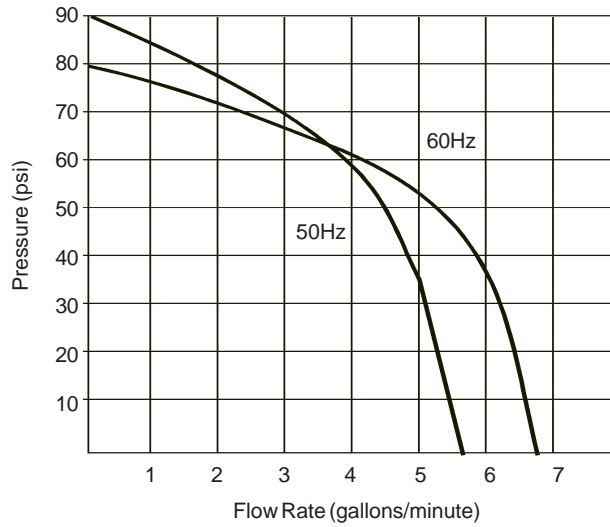

Reservoir Volume

Gallons

1.75

Liters

6.6

Unit Dimensions

(H x W x D)

Inches

30¹/₈ x 16¹/₄ x 20¹/₈

Centimeters

76.5 x 41.3 x 51.1

1. Specifications listed are for a standard unit, +20°C fluid temperature, with tap water as the cooling fluid.

Section III Installation

Site

The unit should be placed in a location with easy access to a cooling water source and a drain.



Never place the unit in a location where excessive heat, moisture, or corrosive materials are present.

Facility Water Requirements



To prevent damage to the unit's inlet and outlet valves, maximum static facility water pressure should not exceed 150 psig and available supply-to-return differential pressure must not exceed 60 psid across the rated flow range.

Refer to the Cooling Capacity chart in Section II, Specifications. The flow rate of the cooling water supply must meet or exceed these requirements for the unit to operate at its full rated capacity. If the cooling water does not meet these standards, the cooling capacity will derate. The chart is based on a 10°C difference between the temperature of the cooling water supply (house water) and the cooling fluid supplied to the instrument being cooled.

As the heat load increases, the required flow rate of the cooling water supply increases. For example, if the heat load is 12 kilowatts, only 2.75 gallons per minute is required to remove the heat. However, if the heat load is 30 kilowatts, about 8.5 gallons per minute is required.

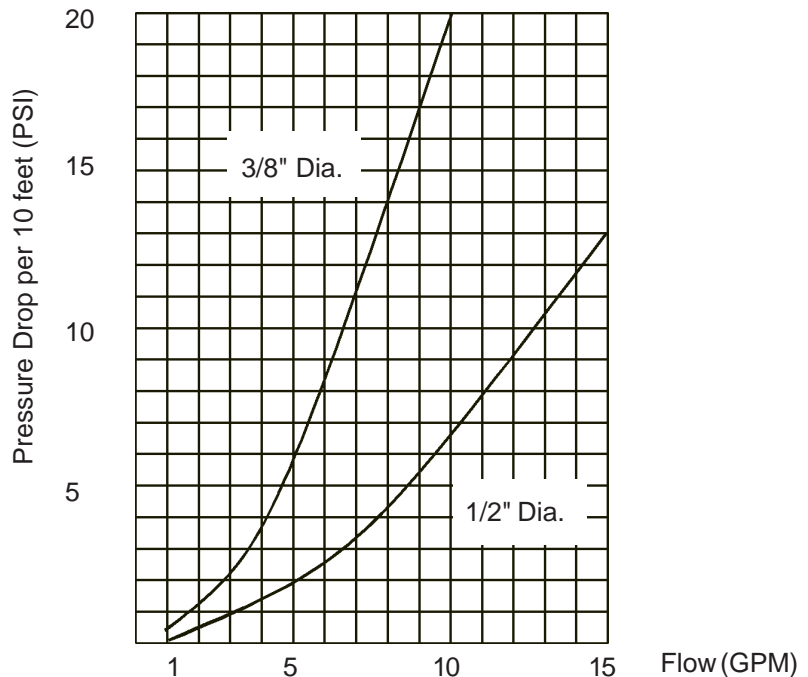

Approximate pressure drop through copper or plastic tubing at given flow rates.

Electrical Requirements



The unit construction provides protection against the risk of electric shock by grounding appropriate metal parts. The protection may not function unless the power cord is connected to a properly grounded outlet. It is your responsibility to assure a proper ground connection is provided.

Refer to the serial number label on the rear of the unit to identify the specific electrical requirements of your unit.

Ensure the voltage of the power source meets the specified voltage, $\pm 10\%$.

Plumbing Requirements

Before installing the unit to an instrument that previously used tap water as a cooling fluid, flush the instrument several times to remove any rust or scale that has built up. The manufacturer of the instrument should be able to recommend a cleaning fluid for their equipment.

The plumbing connections are located on the rear of the unit and are labelled COOLING WATER and PROCESS WATER. The COOLING WATER connections are $\frac{1}{2}$ inch FPT. The PROCESS WATER connections are $\frac{3}{4}$ inch MPT.

Connect the COOLING WATER connections to the cooling water supply.

Connect the PROCESS WATER connections to the instrument being cooled.

Flexible tubing, if used, should be of heavy wall or reinforced construction. All tubing should be rated to withstand 80 psi at $+35^{\circ}\text{C}$. Make sure all tubing connections are securely clamped. Avoid running tubing near radiators, hot water pipes, etc. If substantial lengths of tubing are necessary, insulation may be required to prevent loss of cooling capacity.

Tubing and insulation are available from Thermo Fisher. Contact our Sales Department for more information (see Preface, After-sale Support).

It is important to keep the distance between the unit and the instrument being cooled as short as possible, and to use the largest diameter tubing practical. Tubing should be straight and without bends. If diameter reductions must be made, they should be made at the inlet and outlet of the instrument being cooled, not at the unit.

If substantial lengths of cooling lines are required, they should be pre-filled with cooling fluid before connecting them to the unit.

Fluids



Never use flammable or corrosive fluids with this unit. Do not use automotive anti-freeze. Commercial anti-freeze contains silicates that can damage the pump seals. Use of automotive anti-freeze will void the manufacturer's warranty.

We recommend using distilled/deionized water with a 0.05 to 0.1 MOhmcm reading.



Highly distilled/deionized water, above the 3 MOhmcm region, may become aggressive and is not recommended for use with units with wetted parts other than stainless steel. Distilled/deionized water in the 15 MOhmcm region is definitely aggressive and should not be used. Units operating in these regions should be closely monitored. See Water Quality Standards and Recommendations on the next page.

If you do not have access to distilled/deionized water we recommend using filtered tap water. We cannot recommend any custom fluids, these fluids are too dependent on your particular application.

Below +8°C, a non-freezing solution is required. The selected cooling fluid must have a viscosity of 50 centistokes or less. A 50/50 mixture, by volume, of distilled/deionized water and laboratory grade ethylene glycol is suggested.

Filling Requirements

The reservoir access cover is located on top of the unit. Fill the reservoir to within 1 inch of the top. Keep extra cooling fluid on hand until the entire system (the System II, the instrument being cooled and the tubing that connects them) is filled.

Water Quality Standard and Recommendations

	Permissible (PPM)	Desirable (PPM)
Microbiologicals (algae, bacteria, fungi)	0	0
Inorganic Chemicals		
Calcium	<40	<0.6
Chloride	<250	<25
Copper	<1.3	<1.0
Iron	<0.3	<0.1
Lead	<0.015	0
Magnesium	<12	<0.1
Manganese	<0.05	<0.03
Nitrates\Nitrites	<10 as N	0
Potassium	<20	<0.3
Silicate	<25	<1.0
Sodium	<20	<0.3
Sulfate	<250	<50
Hardness	<17	<0.05
Total Dissolved Solids	<50	<10
Other Parameters		
pH	6.5-8.5	7-8
Resistivity	0.01*	0.05-0.1*

* MOhmcm (Compensated to 25°C)

Unfavorably high total ionized solids (TIS) can accelerate the rate of galvanic corrosion. These contaminants can function as electrolytes which increase the potential for galvanic cell corrosion and lead to localized corrosion such as pitting. Eventually, the pitting could become so extensive that leaking will occur between the process water and facility water diminishing the System's heat transfer capability.

High water hardness (Calcium and Maganese) can also produce scaling. Scaling will inhibit heat transfer between the process and facility side by building up a deposit layer on metal surfaces. As an example, raw water in the United States averages 171 ppm (of NaCl). The recommended level for use in a water system is between 0.5 to 5.0 ppm (of NaCl).

Recommendation: Initially fill the tank with distilled/deionized water. Do not use untreated tap water as the total ionized solids level may be too high.

Maintain this water quality at a resistivity of between 1 to 10 MOhmcm (compensated to 25°C) by using a purification system. Although the initial fill may be as high as 10 MOhmcm (compensated to 25°C), the desired level for long time usage is 1 to 3 MOhmcm (compensated to 25°C).

The above two recommendations will reduce the electrolytic potential of the water and prevent or reduce the galvanic corrosion observed.

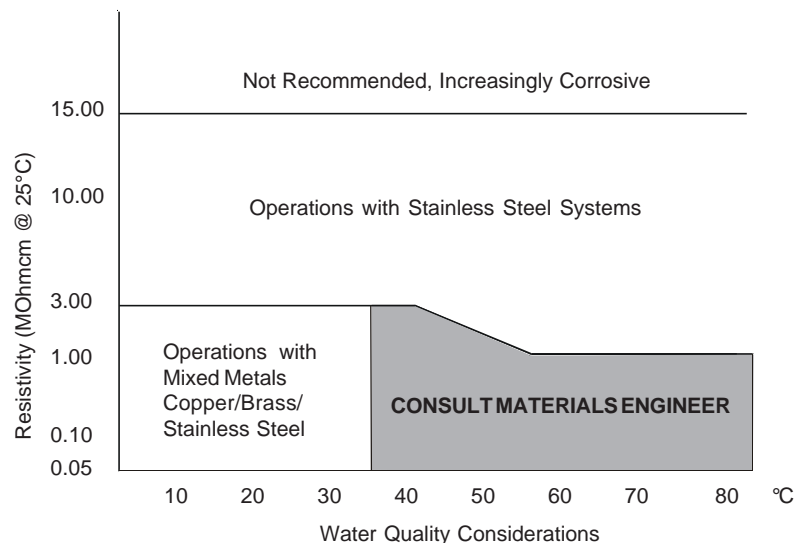

Section IV Operation

Start Up

Before starting the unit, check all electrical and plumbing connections and make sure the circulating system has been properly filled with cooling fluid.

Ensure the facility water is turned on.

To start, momentarily place the OFF/ON/START switch in the START position. The recirculation pump will start and the POWER ON lamp will light.

If the unit does not continue to run when the OFF/ON/START switch is released, check the fluid level in the reservoir. The float switch in the reservoir prevents the unit from operating if the fluid level in the reservoir is below the operating level. If the fluid level is low, "top off" the reservoir.

Temperature Adjustment

A control valve, located in the COOLING WATER INLET line, regulates the flow rate of the cooling water supply as it enters the unit. The valve regulates the flow rate based on the heat load.

The temperature of the cooling fluid is adjusted by turning the recessed valve screw located on top of the unit. Adjust the screw by inserting a screwdriver through the hole in the top. Turn the screw counterclockwise to increase the temperature of the cooling fluid, clockwise to decrease the temperature.

The TEMPERATURE gauge on the front of the unit indicates the temperature of the fluid in the reservoir.

When selecting an operating temperature, remember that the lowest achievable temperature is a function of the available flow rate, the temperature of the cooling water supply, the heat load and the cooling fluid.

Section V Special Features

Low Fluid Level Monitor

The low fluid level monitor is connected to a float switch in the reservoir. A low fluid level fault occurs when the cooling fluid in the reservoir drops below the operating level.

In the event of a low fluid level fault, the unit will shut down, and the INTERLOCK contacts will open. For proper operation, the cause of the fault must be identified and corrected before the unit can be restarted, the fluid level must be returned to the proper operating level.

High Temperature Monitor

The high temperature monitor (HTC) is connected to a sensor that monitors the cooling fluid temperature as it exits the heat exchanger. The monitor protects the system from exposure to excessively hot cooling fluid. A temperature fault occurs when the cooling fluid temperature exceeds the set temperature limit.

In the event of a high temperature fault, the unit will shut down, and the INTERLOCK contacts will open. The cause of the fault must be identified and corrected before the unit can be restarted.

The monitor is not pre-set and must be adjusted during initial installation. The monitor is located on the rear of the unit.

A slotted adjustment screw is located in the center of the monitor. A temperature range scale surrounds the adjustment screw. The temperature scale is in °F.

To adjust the monitor, turn the adjustment screw until the pointer on the temperature scale corresponds to the desired temperature limit. We recommend a temperature limit approximately 50°F higher than the operating temperature.

INTERLOCK Contacts

A set of relay contacts is connected to a receptacle on the front panel. The contacts are rated 10A, 250V. This is not a power inlet or outlet. The receptacle is isolated from the circuitry. Its ground pin is connected to the chassis. The contacts are normally open: they are closed during normal operation and open when the unit is turned off or when a fault occurs.

Pressure Relief Valve

The pressure relief valve establishes the maximum operating pressure of the unit. If the pressure of the fluid leaving the pump exceeds the valve setting, the relief valve will bypass the fluid within the unit to relieve the pressure. The relief valve does not determine the actual operating pressure; the operating pressure of the system is determined by the back pressure of the connected equipment and the setting of the flow control.

If adjustment is necessary, contact our Customer Service Department.

For applications requiring maximum pressure less than 55 psi, a retrofittable External Pressure Reducer (EPR) is available. An EPR allows operating pressures of 10 to 50 psi. Contact our Sales Department for more information (see Preface, After-sale Support). Before calling please obtain the following information:

Part number

Serial number

Section VI Maintenance

Service Contracts

Thermo Fisher Scientific offers on-site Service Contracts that are designed to provide extended life and minimal down-time for your unit. For more information, contact our Service Department (see Preface, After-sale Support).

Cleaning

Periodically inspect the reservoir. If cleaning is necessary, flush the reservoir with a cleaning fluid compatible with the circulating system and the cooling fluid.

Algae

To restrict the growth of algae in the reservoir, it is recommended that the reservoir cover be kept in place and that all circulation lines be opaque. This will eliminate the entrance of light which is required for the growth of most common algae.

We recommend the use of Chloramine-T, 1 gram per 3.7 liters.

Pump Strainer

If debris is in the system, the strainer will prevent the material from being drawn into the pump and damaging the pump vanes.

After initial installation, the strainer may become clogged with debris and scale. Therefore, the strainers must be cleaned after the first week of installation. Before cleaning, disconnect the line cord from the power source and drain the reservoir.

After this first cleaning, a monthly visual inspection is recommended. After several months, the frequency of cleaning will be established.

PD-2 Pumps

Remove the unit's wrapper. The strainer for units equipped with PD-2 pumps is located in each pump's suction line (under the hex nut). Unscrew the strainer and rinse it with water. Replace the strainer.

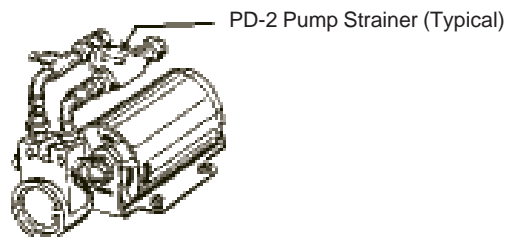

TU-3 Pumps

The strainer for units equipped with an optional TU-3 pumps is located inside the reservoir, directly under the reservoir access cover. Cover the strainer with a plastic bag to trap any debris which may become dislodged. Unscrew the strainer and rinse it with water. Replace the strainer.

Facility Water Strainer (Optional)

The facility water strainer is a user-installed basket strainer on the FACILITY WATER inlet. Clean the strainer when it becomes clogged or dirty.

Disconnect the power cord from the power source and turn off the facility water. Place a container under the strainer to collect any water spills out of the basket when it is removed.

Unscrew the clear plastic basket. Remove the screen and rinse it with water. Replace the screen and the basket.

Pump Motor Lubrication

Some PD-2 pump motors requires pump lubrication. These motors use sleeve type bearings with large oil reservoirs. Oiling instructions are generally posted on each motor. In the absence of legible lubrication instructions, add approximately 30 to 35 drops of SAE 20 non-detergent oil to each bearing on the following schedule (SAE 20 = 142 CS viscosity):

Duty Cycle	Oiling Frequency
Continuous	Every year
Intermittent	Every 2 years
Occasional	Every 5 years

PD-2 Lubrication Fill Holes (Typical)

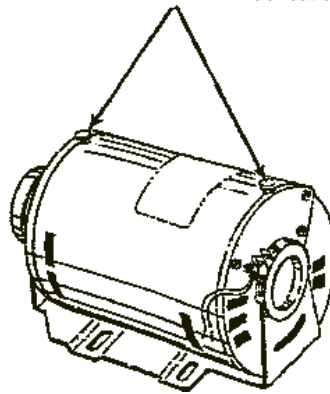

Flow Diagrams

2 PD2 Single Loop

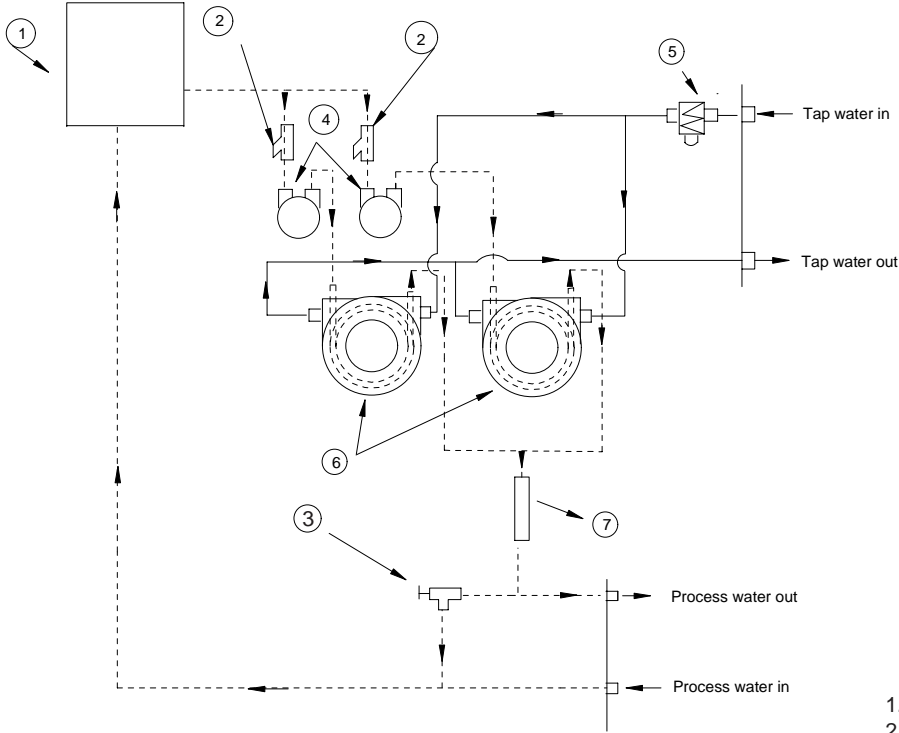

- 1. Tank
- 2. Strainer (009334)
- 3. Relief Valve (009058)
- 4. PD2 Pump (008143)
- 5. Penn Valve (009001)
- 6. Heat Exchangers (054036)
- 7. Temperature Sensor

2 PD2 Double Loop

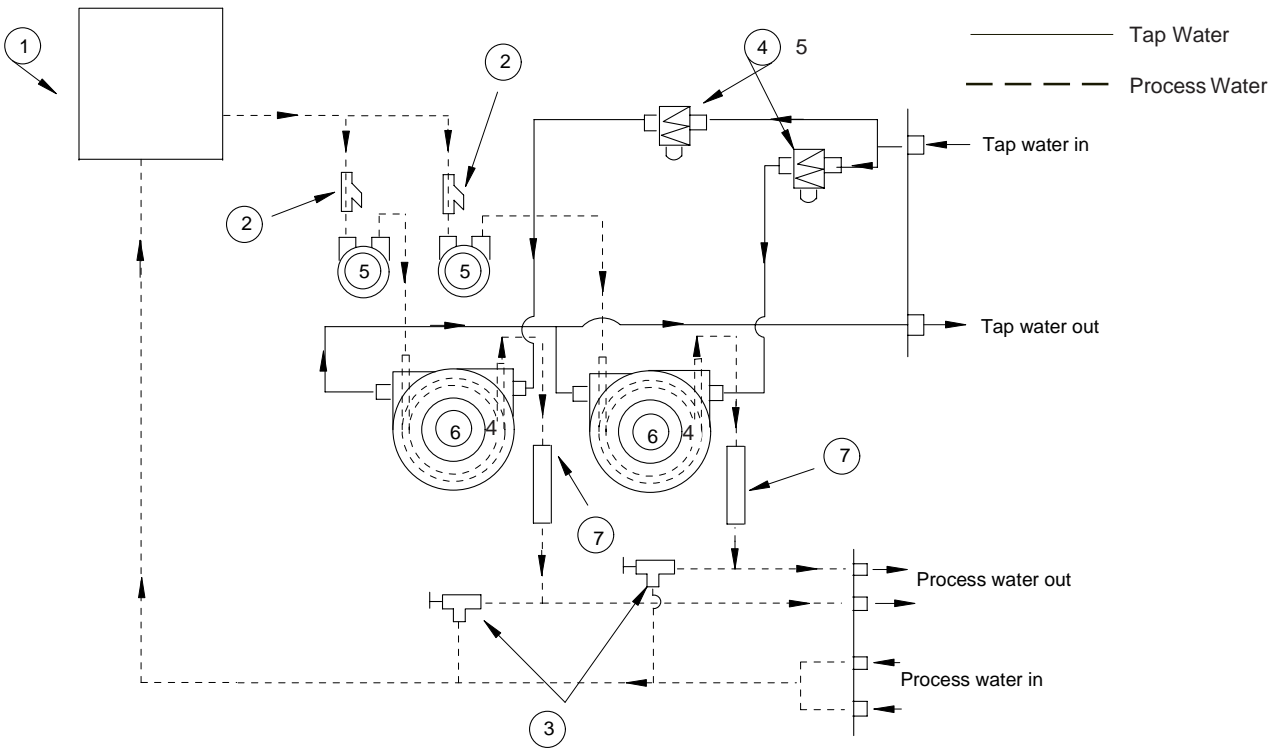

————— Tap Water
 - - - - - Process Water

Section VII Troubleshooting

Checklist

Unit will not run

Make sure the voltage of the power source meets the specified voltage, $\pm 10\%$. Refer to the serial number on the rear of the unit for the specific electrical requirements of your unit.

On units with a REMOTE/LOCAL switch, ensure the switch is in the correct position.

Unit runs when OFF/ON/START button is in START position, but stops when button is released.

Hold switch in START position for longer period of time.

Check for proper reservoir level. The float switch in the reservoir prevents the unit from operating if the fluid level in the reservoir is below the operating level. If the fluid level is low, "top off" the reservoir and restart the unit.

Make sure the high temperature monitor is set higher than the temperature of the cooling fluid.

Check the fuse on the circuit board inside the control box. The fuse is 0.5 Amp 250 V slow-blow.

Unit runs for a short period, then stops.

Check the fluid level in the reservoir. If it is low, check the system for leaks.

Make sure the heat load is not greater than the cooling capacity of the unit (see Section II, Cooling Capacity).

Make sure the cooling water supply meets the requirements outlined in Section III, Facility Water Requirements.

A possible power interruption has occurred, causing the "latch" relay to unlatch. Attempt to restart.

Unit "chatters"/vibrates

Adjust your facility water supply-to-return differential pressure to the unit.

Service Assistance

If, after following these troubleshooting steps, your unit fails to operate properly, contact our Service Department for assistance (see Preface, After-sale Support). Before calling please obtain the following information:

Part number

Serial number

Voltage of unit

Voltage of power source

Temperature at which the problem occurs

Temperature, pressure, and flow rate of cooling water supply

Our Service Department can provide you with a wiring diagram and a complete list of spare parts for your unit.

WARRANTY

Thermo Fisher Scientific warrants for 12 months from date of shipment any Thermo Scientific product according to the following terms.

Any part of the unit manufactured or supplied by Thermo Fisher and found in the reasonable judgment of Thermo Fisher to be defective in material or workmanship will be repaired at an authorized Thermo Scientific Product Repair Depot without charge for parts or labor. The unit, including any defective part must be returned to an authorized Thermo Scientific Product Repair Depot within the warranty period. The expense of returning the unit to the authorized Thermo Scientific Product Repair Depot for warranty service will be paid for by the buyer. Our responsibility in respect to warranty claims is limited to performing the required repairs or replacements, and no claim of breach of warranty shall be cause for cancellation or rescission of the contract of sales of any unit. With respect to units that qualify for field service repairs, Thermo Fisher Scientific's responsibility is limited to the component parts necessary for the repair and the labor that is required on site to perform the repair. Any travel labor or mileage charges are the financial responsibility of the buyer.

The buyer shall be responsible for any evaluation or warranty service call (including labor charges) if no defects are found with the Thermo Scientific product.

This warranty does not cover any unit that has been subject to misuse, neglect, or accident. This warranty does not apply to any damage to the unit that is the result of improper installation or maintenance, or to any unit that has been operated or maintained in any way contrary to the operating or maintenance instructions specified in this Instruction and Operation Manual. This warranty does not cover any unit that has been altered or modified so as to change its intended use.

In addition, this warranty does not extend to repairs made by the use of parts, accessories, or fluids which are either incompatible with the unit or adversely affect its operation, performance, or durability.

Thermo Fisher Scientific reserves the right to change or improve the design of any product without assuming any obligation to modify any unit previously manufactured.

THE FOREGOING EXPRESS WARRANTY IS IN LIEU OF ALL OTHER WARRANTIES, EXPRESSED OR IMPLIED, INCLUDING BUT NOT LIMITED TO WARRANTIES OR MERCHANTABILITY AND FITNESS FOR A PARTICULAR PURPOSE.

Thermo Fisher Scientific's OBLIGATION UNDER THIS WARRANTY IS STRICTLY AND EXCLUSIVELY LIMITED TO THE REPAIR OR REPLACEMENT OF DEFECTIVE COMPONENT PARTS AND Thermo Fisher DOES NOT ASSUME OR AUTHORIZE ANYONE TO ASSUME FOR IT ANY OTHER OBLIGATION.

Thermo Fisher ASSUMES NO RESPONSIBILITY FOR INCIDENTAL, CONSEQUENTIAL, OR OTHER DAMAGES INCLUDING, BUT NOT LIMITED TO LOSS OR DAMAGE TO PROPERTY, LOSS OF PROFITS OR REVENUE, LOSS OF THE UNIT, LOSS OF TIME, OR INCONVENIENCE.

This warranty applies to units sold in the United States. Any units sold elsewhere are warranted by the affiliated marketing company of Thermo Fisher Scientific. This warranty and all matters arising pursuant to it shall be governed by the law of the State of New Hampshire, United States. All legal actions brought in relation hereto shall be filed in the appropriate state or federal courts in New Hampshire, unless waived by Thermo Fisher Scientific.