

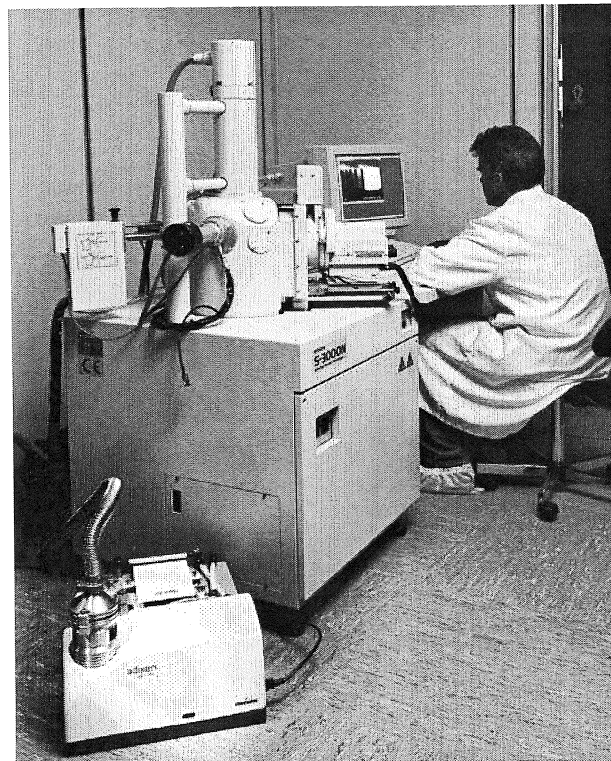

Alcatel Vacuum Technology, as part of the Alcatel Group, has been supplying vacuum pumps, leak detection systems, vacuum measurement and micro machining systems for several years. Thanks to its complete range of products, the company has become an essential player in multiple applications : instrumentation, Research & Development, industry and semiconductors. Alcatel Vacuum Technology has launched Adixen, its new brand name, in recognition of the company's international standing in vacuum position. With both ISO 9001 and 14001 certifications, the French company is an acknowledged expert in service and support, and Adixen products have the highest quality and environmental standards.



With 40 years of experience, AVT today has a worldwide presence, through its international network that includes a whole host of experienced subsidiaries, distributors and agents. The first step was the founding of Alcatel Vacuum Products (Hingham- MA) in the United States, thirty years ago, reinforced today by 2 others US subsidiaries in Fremont (CA) and Tempe (AZ). In Europe, AVTF-France headquarters and three of its subsidiaries, Alcatel Hochvakuumtechnik (Germany), Alcatel Vacuum Technology UK (Scotland) and Alcatel Vacuum Systems (Italy) form the foundation for the European partner network. In Asia, our presence started in 1993 with Alcatel Vacuum Technology (Japan), and has been strengthened with Alcatel Vacuum Technology Korea (in 1995), Alcatel Vacuum Technology Taiwan (in 2001), Alcatel Vacuum Technology Singapore, and more recently with Alcatel Vacuum Technology Shanghai (China) (in 2004). This organization is rounded off by more than 40 representatives based in a variety of continents.

Thus, whatever the circumstances, the users of Adixen products can always rely on quick support of our specialists in Vacuum Technology.

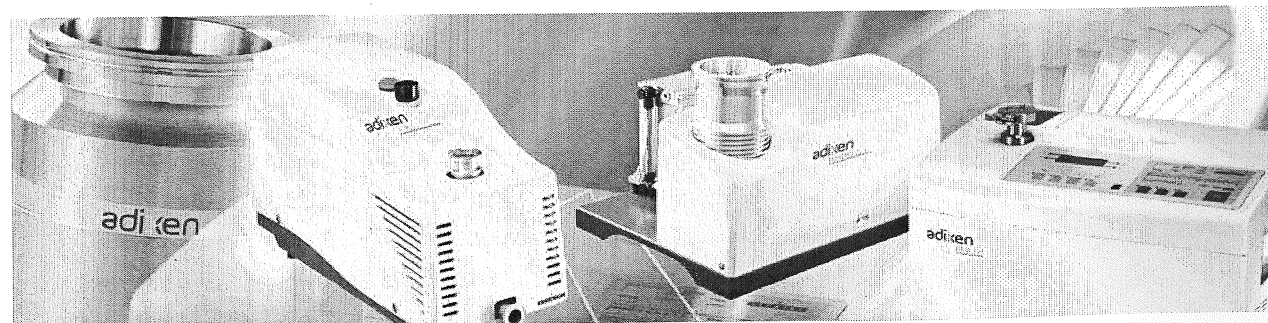

## User's manual ACP series dry primary pumps

### Welcome

Dear customer,

You have just purchased an Adixen dry primary pump. We would like to thank you and are proud to count among our customers.

This product benefits from Alcatel's many years of experience in producing vacuum products in many applications like Instrumentations, R & D, Semi-conductors process. In the last field, thousands of dry pumps, based on the ACP technology are currently running.

**In order to guarantee performance and obtain full satisfaction from this equipment, we suggest that you study this manual, particularly chapter B devoted to installation and start-up, before installing or performing maintenance on your pump.**

#### APPLICATIONS:

ACP 15, ACP 28 AND ACP 40 DRY PRIMARY PUMPS FOR «CLEAN» APPLICATIONS

- Instrumentation
- Research and Development
- Semi-conductors: Load lock - Transfer chamber

ACP 15 G, ACP 28 G, ACP 40 G DRY PRIMARY PUMPS FOR THE PUMPING OF CORROSIVE GAS TRACES.

#### FEATURES:

MULTI-STAGE ROOTS TECHNOLOGY  
UNIVERSAL SINGLE PHASE ELECTRICAL SUPPLY  
AIR COOLED

MANUAL REFERENCE: 109 125  
EDITION: 07 - MARCH 2006

# User's manual ACP series dry primary pumps

This product complies with the requirements of European Directives, listed in the Declaration of Conformity contained in G100 of this manual. These Directives are amended by Directive 93/68/E.E.C (E.C. Marking). The Declaration of Conformity with the Safety Instructions is available at the end of the manual.

Copyright/Intellectual property:  
The use of Adixen products are subject to copyright and intellectual property rights in force in any jurisdiction. All rights reserved, including copying this document in whole or any part without prior written authorization from Alcatel Vacuum Technology France.

Specifications and information are subject to change without notice by Alcatel Vacuum Technology France.

GB 00685 - Edition 07 - March 06

MANUAL REFERENCE: 109125  
EDITION: 07 - March 2006

# General contents ACP Series User's Manual

## Chapter A

### INTRODUCTION

- A 10 - ACP Series dry primary pumps overview
- A 20 - Operating principle
- A 30 - Dry primary pump applications
- A 40 - Technical characteristics - ACP 15
- A 41 - Technical characteristics - ACP 28, ACP 40
- A 50 - Accessories

## Chapter B

### INSTALLATION

- B 00 - Safety instructions
- B 10 - Installation of ACP Series pumps
- B 20 - Mechanical connections
- B 30 - Electrical connections
- B 40 - Remote control connector wiring
- B 50 - Inert gas purge connection (G version)

## Chapter C

### OPERATION

- C 10 - Pump operation

## Chapter D

### MAINTENANCE - TROUBLESHOOTING

- D 10 - Maintenance frequency
- D 20 - Instructions for cleaning

## Chapter E

### MAINTENANCE SHEETS

- E 00 - Maintenance safety instructions
- E 10 - Procedure for returning vacuum pumps

## Chapter F

### COMPONENTS

- F - Non used

## Chapter G

### APPENDIX

- G 10 - ACP 15 / 15 G - Pumping curves
- G 11 - ACP 28 / 28 G - Pumping curves
- G 12 - ACP 40 / 40 G - Pumping curves
- G 30 - Safety questionnaire
- G 40 - Analysis questionnaire
- G 100 - Declaration of Conformity



WARNING

**Warnings are used when failure to observe instructions could result in injury or death.**



CAUTION

**Cautions are used when failure to observe instructions could result in significant damage to equipment and/or facilities.**

# ACP Series

Dry primary pumps

**User's Manual**

## ACP Series dry primary pump overview

### Superior technology

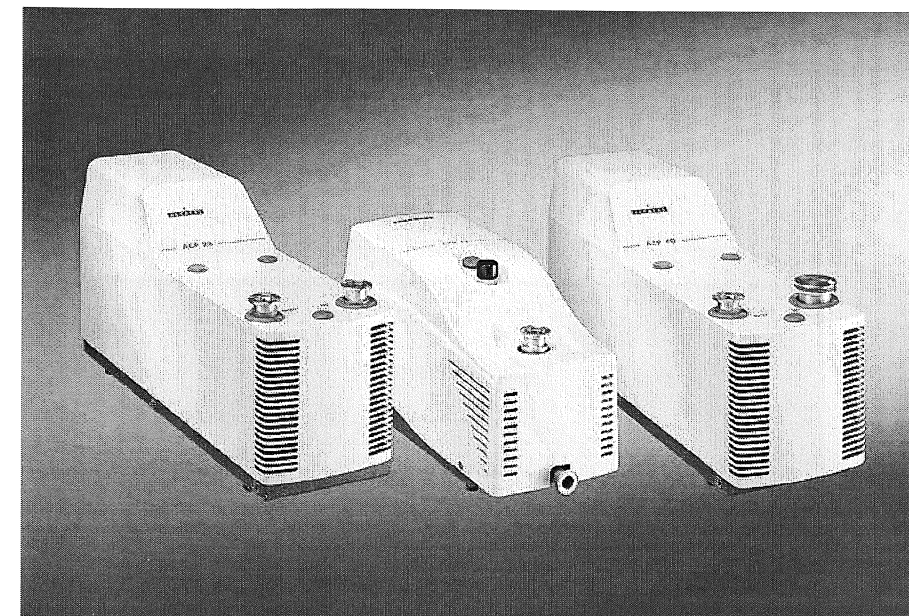

- Type Multi-stage Roots primary pump
  - frictionless technology
  - reliability
  - aluminium pump body
- Dry and clean vacuum
  - no particulate contamination
  - residual gas spectrum free of traces of hydrocarbons
- Sealed air-cooled motor
  - permanent air cooling (built-in fan)
  - safety: certified leaktight
- Single-phase frequency converter
  - multi-voltage, dual frequency 50/60 Hz
- 2 pump models according to different applications
  - standard version
  - G version
- Thermal protection based on temperature sensors.

ACP Series dry primary pump overview

Model ACP 15 / 15 G overview

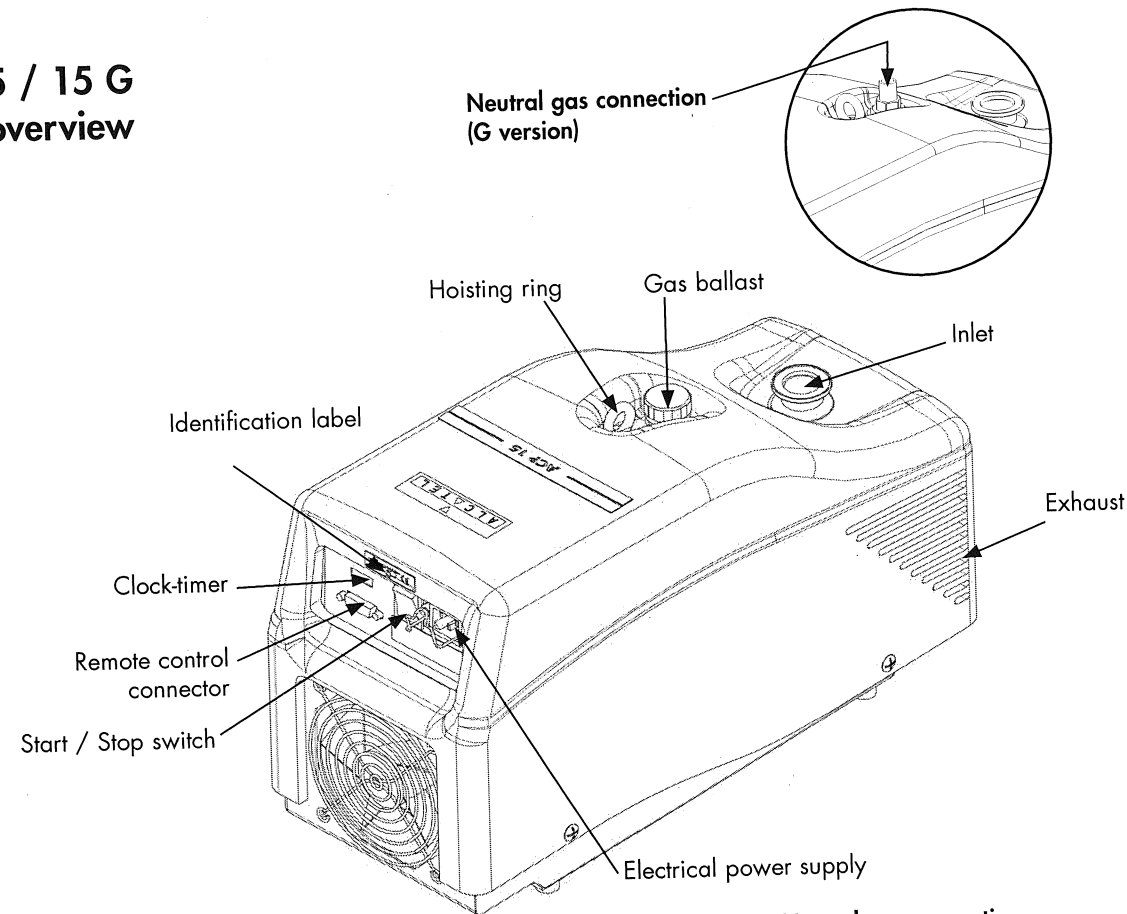

Models ACP 28 / 28 G / 40 / 40 G overview

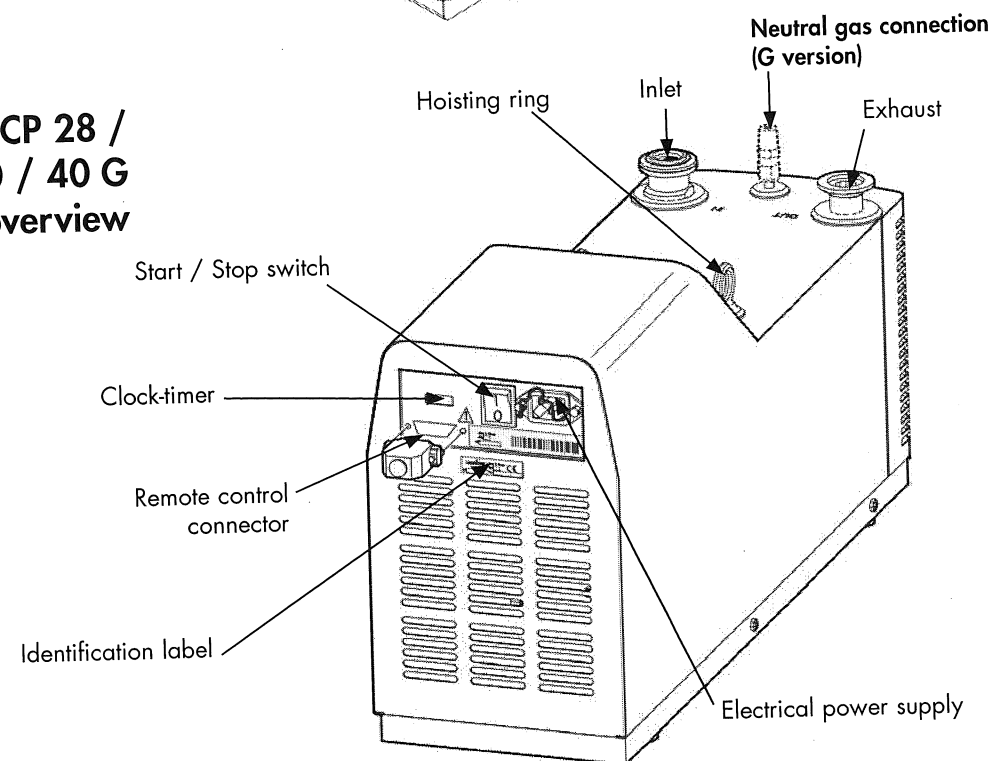

Operating principle

Multi-stage Roots principle

- The ACP pumps are composed of 5 or 6 Roots type stages, connected in series.
- No contact design. The rotors do not touch each other or the housing.

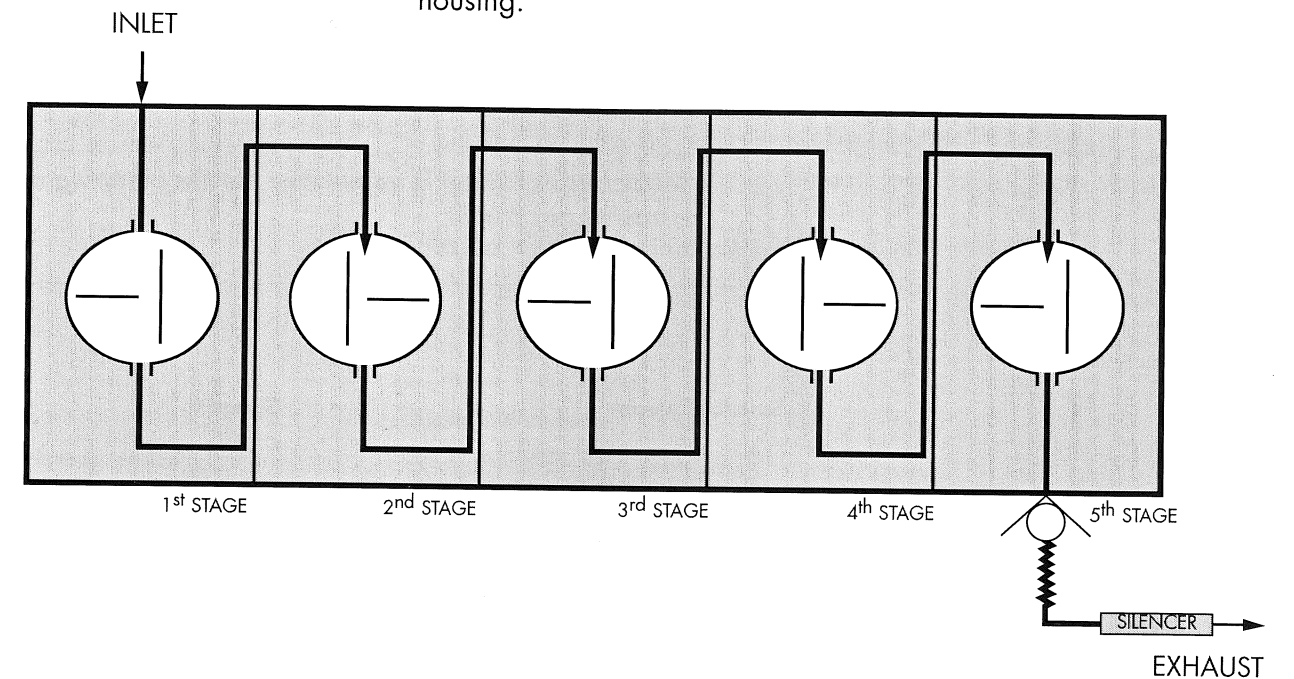

- The ACP15 pump is equipped with a gas ballast device to improve pumping of light gases and condensable vapors. Thus avoiding condensation of pumped gases into the pump.

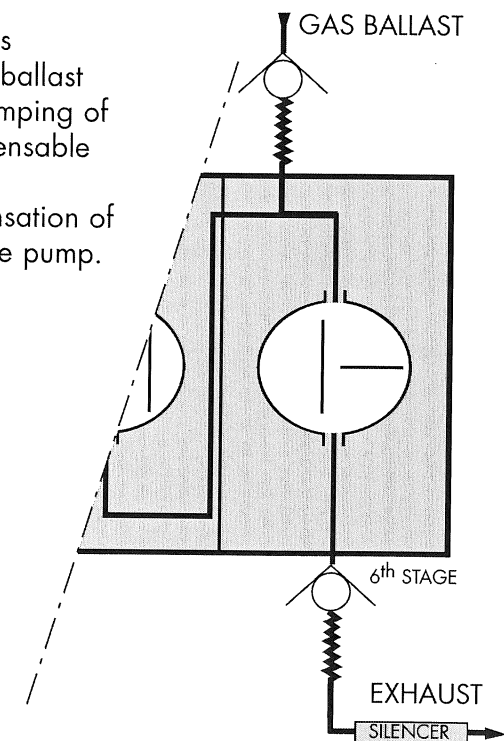

## Operating principle

### Leak-tightness on low pressure bearings

On the low pressure side of the pump, ball bearings are lubricated with grease that is resistant to high temperatures and corrosion.  
 On G version, an over pressure area is created around the bearings by injecting a neutral gas.  
 This pressurization prevents pumped gases from migrating towards the bearings.



**Neutral gas purging is imperative for the pumping of corrosive gas traces.**

Standard version

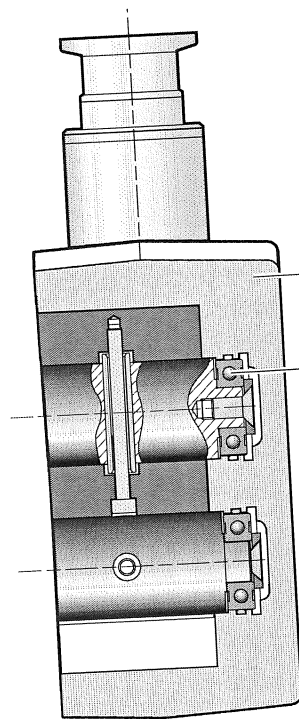

- 1 - Gas purge
- 2 - Inlet stage
- 3 - Lips seal

G version

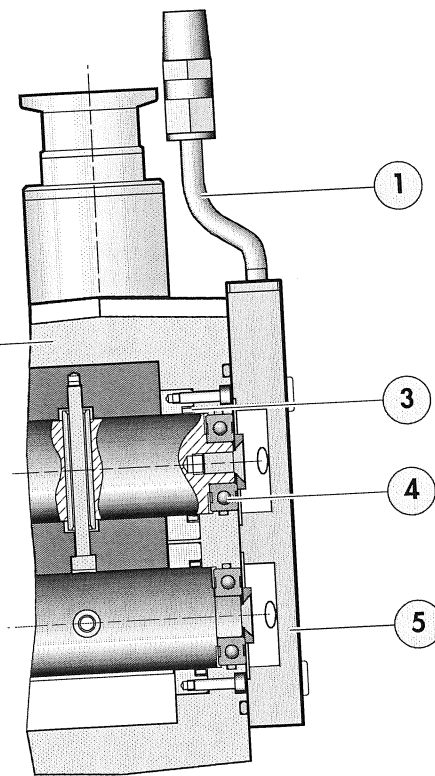

- 4 - Ball bearings
- 5 - Injection plate

## Operating principle

### Leak-tightness on high pressure bearings

The rotation of the lubrication plate in an oil bath ensures ball bearings and gears lubrication.

The tightness between the oil casing and the exhaust stage is guaranteed by a deflector, a trap and a double lips seal.

These features have several other functions:

- barrier to pumped gases (protection of the bearings)
- barrier to fluid recovery in the exhaust stage (clean vacuum).

Beside, G version includes a gas injection line.

- 1 - Exhaust stage (HP)
- 2 - HP bearing support
- 3 - Double lips seal
- 4 - Deflector
- 5 - Lubrication plate
- 6 - Gearbox casing
- 7 - Ball bearings
- 8 - Gas purge

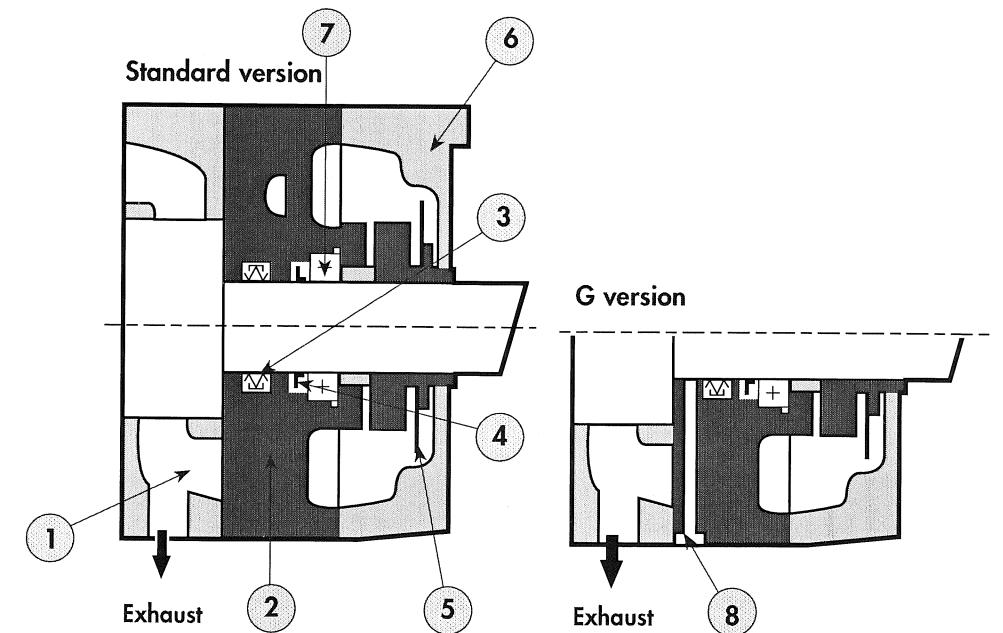

## Dry primary pump applications

### Standard version for "clean vacuum" applications

The pump is designed for applications that require the pumping of clean (dust-free) and non-corrosive gases. Examples are:

- Instrumentation:
  - Gas analysis.
  - Electronic microscope.
  - X-ray spectrometer.
  - Leak detection.
  - Surface analyzer.
- Research and Development
- Semiconductor Fabrication:
  - Load lock and transfer chamber pumping.
  - Wafer back pumping.

### G version for pumping of corrosive gas traces or condensable gas

**G version** pump is compatible with the pumping of corrosive **traces**. It is equipped with 3 gas purge circuits used to withstand gas traces, to protect the LP and HP ball bearings, and the pump thightness is reinforced. This pump model can be used in applications such as:

- Process monitoring.
- Load lock pumping.
- Transfer chamber pumping.
- Focused Ion Beams.

*For corrosive gas pumping contact the manufacturer.*

## Technical characteristics - ACP 15 / ACP 15 G

Specifications	Unit	ACP 15	ACP 15 G
Utilization		Indoor	
Functioning altitude	m (ft)	< 2000 (6561)	
Installation category		II	
Pollution degree		2	
Ultimate pressure - gas ballast closed	mbar (Torr)	$5 \times 10^{-2}$ ( $3.8 \times 10^{-2}$ )	-
Ultimate pressure - Standard model : with gas ballast opened - G model : with purge (300 mbar relative pressure)	mbar (Torr)	$3 \times 10^{-1}$ ( $2.25 \times 10^{-1}$ )	$3 \times 10^{-1}$ ( $2.25 \times 10^{-1}$ )
Peak pumping speed (rotation speed 6000 rpm)	m <sup>3</sup> /h (cfm)	14 (8.2)	
Maximum vibrations transmitted at the inlet (0 to 1000 Hz spectrum)		displacement 5 μm Speed 2.5 mm/s	
Maximum pressure at inlet (absolute)	mbar (Torr)	1013 (760)	
Maximum exhaust pressure (absolute)	mbar (Torr)	1200 (900)	
Max. ambient operating temperature	°C (°F)	+ 40 (+ 104)	
Min. ambient operating temperature	°C (°F)	+ 12 (+ 54)	
Leakage current	mA	< 5	
Power consumption .....at ultimate pressure (gas ballast closed) .....at ultimate pressure (gas ballast opened) .....at atmospheric pressure	W	450 480 500	
Gas ballast flowrate	m <sup>3</sup> /h	0.5	-
N <sub>2</sub> flowrate*	slm	-	5
Single phase power Automatic switch voltage (high or low)		110 / 230 V ± 10% - 50/60 Hz 10/15 A - 1150 VA	
Fan flow rate	m <sup>3</sup> /h	180	
Inlet port		DN 25 ISO-KF	
Exhaust port		DN 16 ISO-KF	
Oil capacity **	cm <sup>3</sup>	20	
Weight	Kg (lbs)	23 (50.7)	
Storage temperature	°C (°F)	mini -10 (14) / maxi 60 (140)	

\* relative nitrogen pressure 300 mbar

\*\* oil charge has been introduced into oil casing at factory. Don't modify this oil level.

### Dimensional drawing mm (inch)

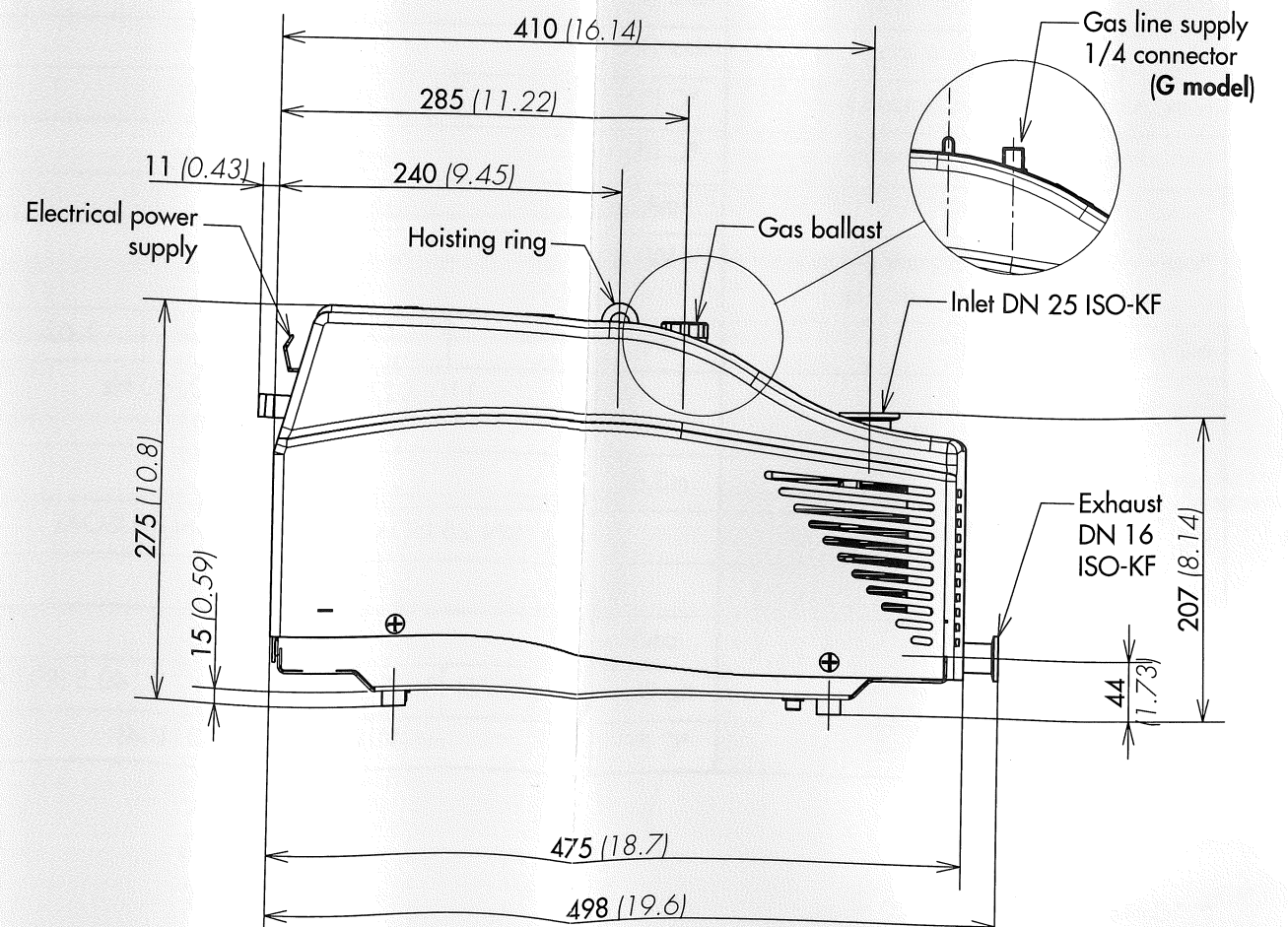
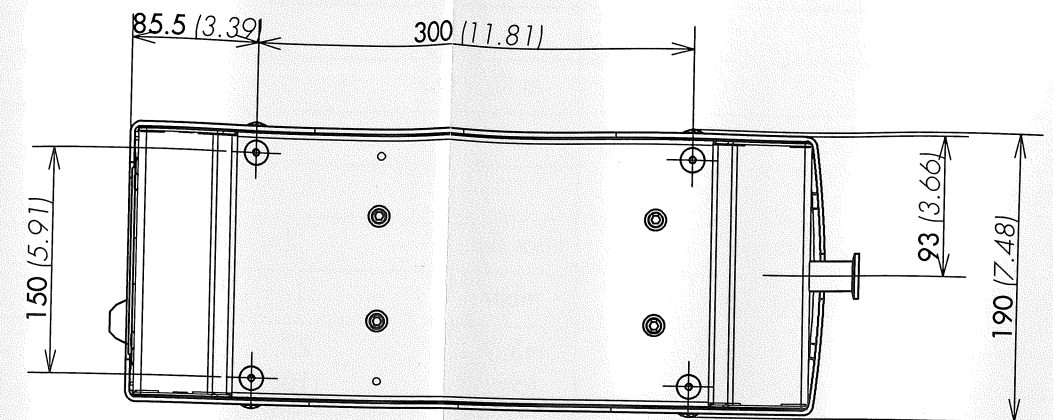



# A 41

## Technical characteristics - ACP 28 / 28 G / 40 / 40 G

### Specifications

	Unit	ACP 28	ACP 28 G	ACP 40	ACP 40 G
Utilisation		Indoor			
Functioning altitude	m (ft)	< 2000 (6561)			
Installation category		II			
Pollution degree		2			
Ultimate pressure without purge	mbar (Torr)	$3 \times 10^{-2}$ ( $2.25 \times 10^{-2}$ )			
Ultimate pressure with purge	mbar	-	$1 \times 10^{-1}$	-	$1 \times 10^{-1}$
Peak pumping speed (rotation speed 4800 rpm)	m <sup>3</sup> /h (cfm)	27 (16)		37 (22)	
Max. vibrations transmitted at the inlet (4 to 400 Hz spectrum)		Max. displacement 3 mm Speed 1 mm/s			
Maximum pressure at inlet (absolute)	mbar (Torr)	1013 (760)			
Maximum exhaust pressure (absolute)	mbar (Torr)	1200 (900)			
Max. ambient operating temperature	°C (°F)	+ 40 (+ 104)			
Min. ambient operating temperature	°C (°F)	+ 12 (+ 54)			
Leakage current	mA	< 5			
Power consumption at ultimate pressure ... at atmospheric pressure	W	700 1200			
N <sub>2</sub> gas purge flowrate*	slm	-	1.65	-	1.65
Single phase power Automatic switch voltage (high or low)		110 / 230 V ± 10% - 50/60 Hz 10 A / 5 A - 1150 VA			
Fan flow rate	m <sup>3</sup> /h	410			
Inlet port		DN 25 ISO-KF		DN 40 ISO-KF	
Exhaust port		DN 25 ISO-KF			
Oil capacity**	cm <sup>3</sup>	25			
Weight	Kg (lbs)	33 (72.75)	33.5 (73.85)	38 (83.79)	40.5 (89.28)
Storage temperature	°C (°F)	mini -10 (14)/ maxi 40 (104)			

GB 00691 - Edition 05 - February 04

\* relative nitrogen pressure 300 mbar.

Don't modify this oil level

### Dimensional drawing mm (inch)

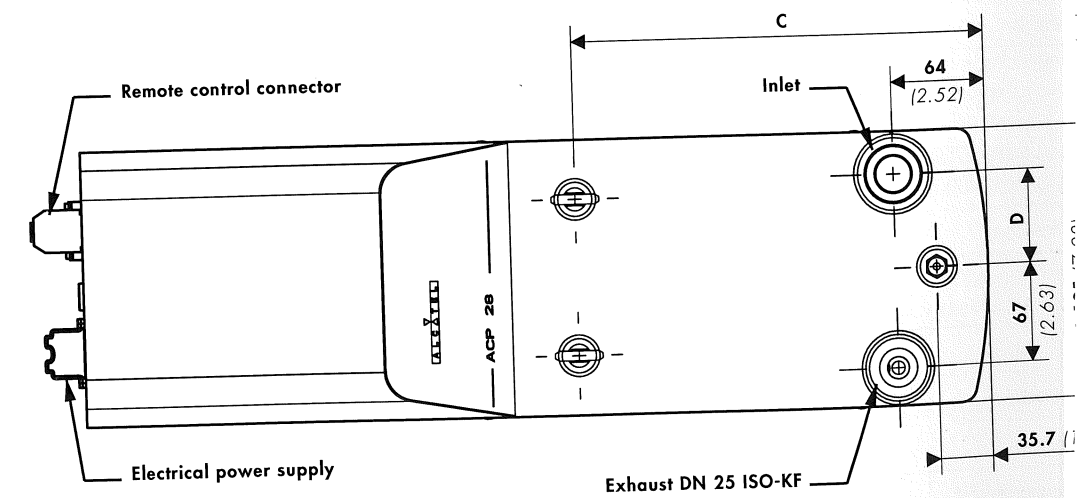
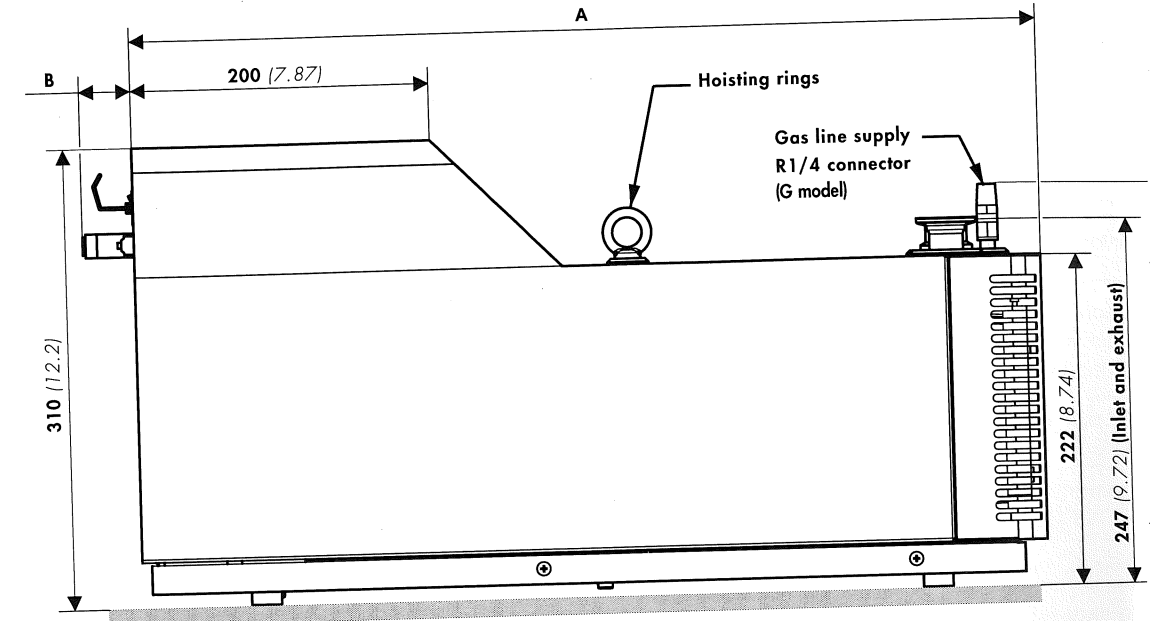

	A	B	C	D	Inlet
ACP 28	609	35	277.7	63.5	DN 25 ISO-KF
ACP 28 G					
ACP 40	634	35	300.7	60	DN 40 ISO-KF
ACP 40 G					

**Dimensional drawing  
mm (inch)**

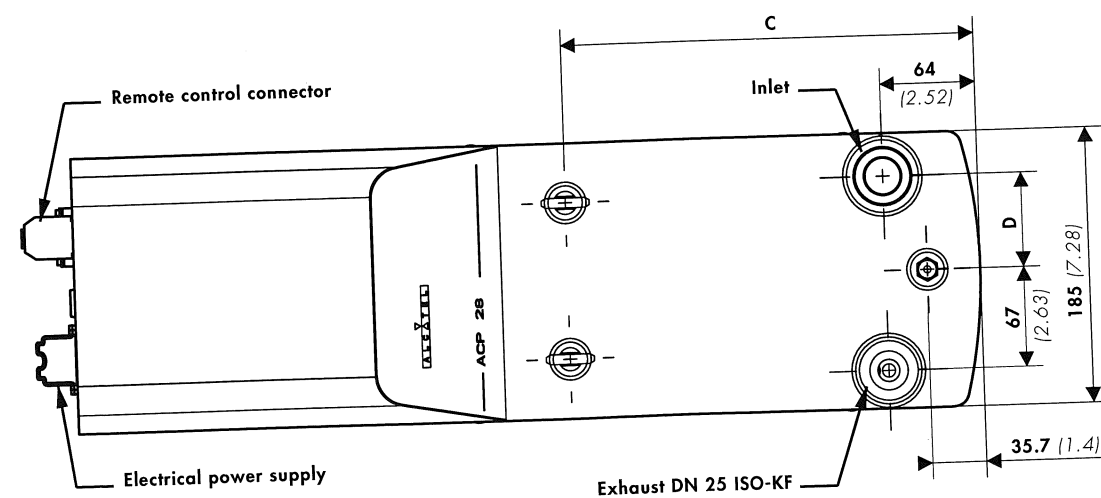
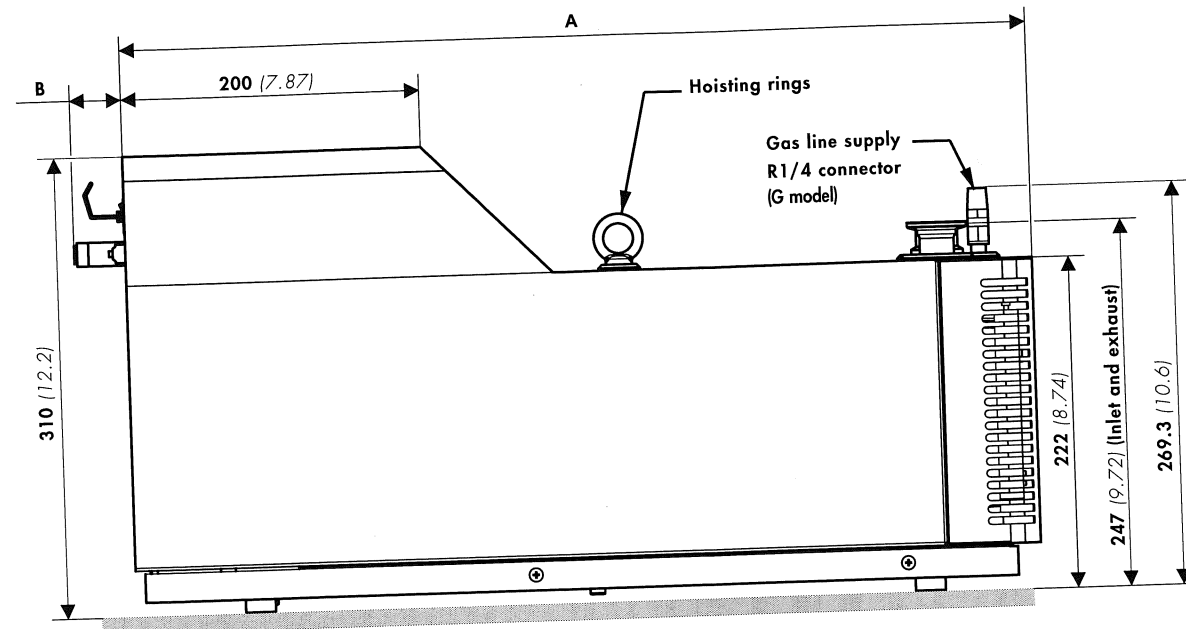

	A	B	C	D	Inlet
ACP 28 ACP 28 G	609	35	277.7	63.5	DN 25 ISO KF
ACP 40 ACP 40 G	634	35	300.7	60	DN 40 ISO KF

**Accessories**

**Inlet filter**

The inlet filter is installed on the pump inlet and collects particles with a diameter greater than 25 microns (vacuum packing, metallurgy, lamp manufacture, evaporation, etc.).

Model	Part number
IPF 25 (for ACP 15/28)	111 649
IPF 40 (for ACP 40)	111 647

**Exhaust silencer**

In order to reduce noise level at the exhaust when the pump is operated at high pressures.

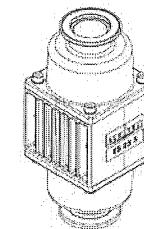

Model	Part number
Silencer ES25S	109 873

**Sound inclosure**

In order to reduce significantly noise level.

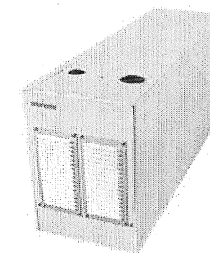

Model	Part number
For pump ACP 28 or ACP 40	110 701
NRC 15 for pump ACP 15	111 968

## Safety instructions



CAUTION

*Before powering up, the user must study the manual, the safety instructions of G 100 and follow instructions "warning" and "caution".*

### Installation and start-up

- Our products are designed to comply with current EC regulations. Any modification of the product made by the user is liable to lead to non-compliance with the regulations, or even to put into doubt the EMC (ElectroMagnetic Compatibility) performance and the safety of the product. The manufacturer declines any responsibility for such operations.
- The EMC performance of the product is obtained on the condition that the installation complies with the EMC rules. In particular, in disturbed environments, it is essential to:

*The performance and the operational safety of this product is guaranteed provided that it is used in normal operating parameters defined in this manual.  
Any modification of the pump not improved by the manufacturer can compromise the protection ensured by the pump.*

- use shielded cables and connections for interfaces,
- stabilize the power supply line with meshing from the power supply source to a distance of 3m from the pump inlet.



WARNING

*When switching off an item of equipment containing capacitors loaded with over 60 VDC or 25 VAC, take precautions at the access to the connector pins (single-phase motors, fitting with mains filter, frequency converter, monitoring system, etc.).*

Safety instructions

Operation



*The pump must be operated in the horizontal position with the pumping axis vertical and the inlet operating upwards.*



*Neutral gas purging is imperative for the pumping of corrosive gas traces.*



*The ACP Series standard version are made to pump on clean gas. The ACP Series G version are made to pump on corrosive gas traces. The manufacturer has no control over the types of gases passing through this pump. Frequently, process gases are toxic, flammable, corrosive, explosive or otherwise reactive. Since these gases can cause serious injury or death, it is very important to plumb the exhaust of the pump to the facility's hazardous gas exhaust system which incorporates appropriate filters, scrubbers, etc., to insure that the exhaust meets all air regulations. Check that pump is correctly connected to the equipment.*



*The maximum inlet pressure is the absolute atmospheric pressure. A pressure too high can damage the pump.*



*Make sure that the exhaust pressure does not exceed 1200 mbar (absolute pressure). A pressure too high can damage the pump.*



*The ACP pumps must not be operated in an area with risk of explosion. Consult us to study a solution.*

Installation of ACP Series pumps

Unpacking

■ When you receive the equipment, unpack it carefully; do not discard the packaging until you have ensured that the pump has not been damaged during transport. Otherwise, take the necessary measures with the transporting company and, if necessary, notify the manufacturer.

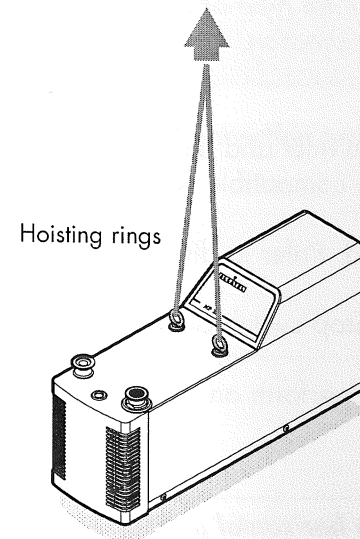

■ For all handling of the equipment, it is highly recommended to use a lifting device. Use the hoisting rings delivered with the pump by screwing them in the threaded holes located on the top side of the pump.

Model type	Weight
ACP 15/15 G	23 Kg
ACP 28	33 Kg
ACP 28G	33,5 Kg
ACP 40	38 Kg
ACP 40 G	40,5 Kg

■ The hoisting rings can be removed from the housing.

Equipment storage

■ If the new pump is to be stored, the plugs on the inlet and exhaust ports must remain in position. The storage temperature must not be below -10 °C.

Ventilation

Vents at both ends of the pump. Place the pump at least 80 mm from the stationary section. The ambient air temperature particularly near the fan must be less than 40 °C.

SINGLE-PHASE

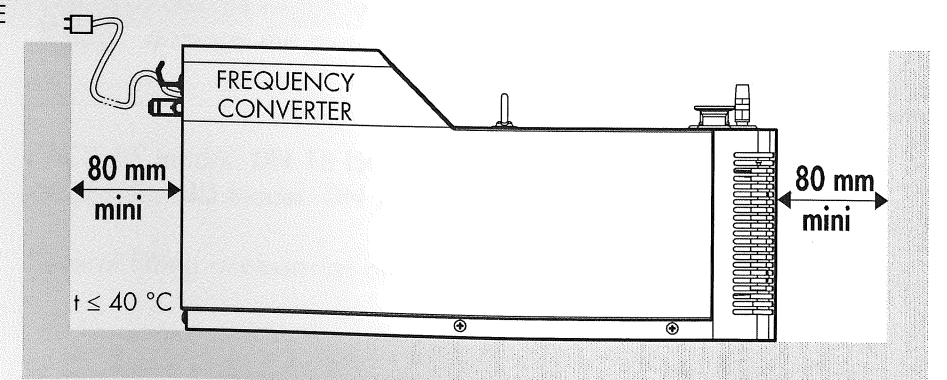

Installation of ACP Series pumps

Installation safety instructions

*The performance of the pump depends on the type of accessories used and the quality of the mechanical connection.*

- For safety reasons, use accessories on the inlet and exhaust lines whose materials and sealing properties are compatible with the gases being used.
- Determine where the pump will be placed. Refer to dimensional diagram in section A 40 or A 41.
- Install the pump in a way that the Start/Stop switch of the pump is accessible for the operator.
- After pump connection, it is necessary to perform an helium leak tightness test.



*The pump must be operated in the horizontal position with the pumping axis vertical and the inlet operating upwards.*

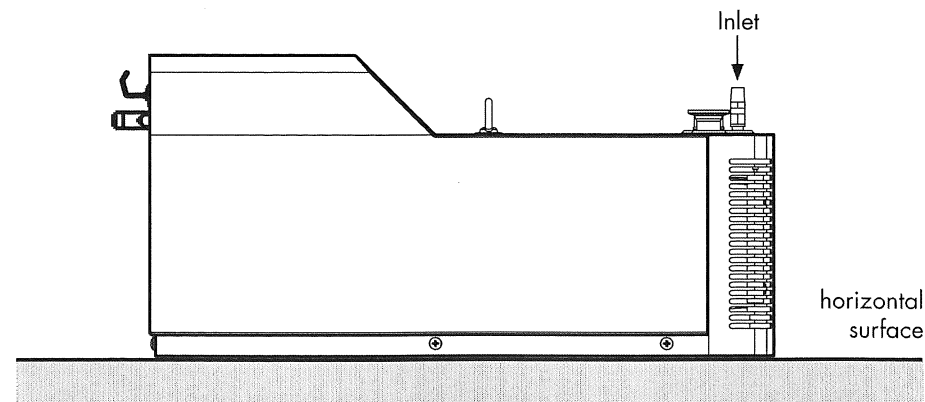

GB 00693 - Edition 05 - March 06

GB 00823 - Edition 05 - March 06

Mechanical connections

**Inlet** Remove the protector from the inlet flange.

Connect the pump inlet to the equipment with connecting accessories (see manufacturer's catalog).

- Connection type**
- ACP 15 / 28 model: DN 25 ISO-KF.
  - ACP 40 model: DN 40 ISO-KF.



*The maximum inlet pressure is the absolute atmospheric pressure. A pressure too high can damage the pump.*



*In case of applications involving dust or solid particules, we recommend to use appropriate inlet filters in order to protect the pump (see section A 50). Also, we advise to use clean fittings and pipings for connecting the pump to the installation.*

**Exhaust** Remove the protector from the exhaust flange.



*When pumping on corrosive gas traces, or aggressive gases (pump G version), the gas can cause injury or death. The exhaust of the pump must be connected to an exhaust stack or an evacuation duct.*



*Make sure that the exhaust pressure does not exceed 1200 mbar (absolute pressure). A pressure too high can damage the pump.*

- Connection type**
- ACP 15 model: DN 16 ISO-KF.
  - ACP 28 / 40 model: DN 25 ISO-KF.

Several fitting accessories are available in the manufacturer's catalog.

## Electrical connections

- General** ■ Our products are designed to comply with current EC regulations. Any modification of the product made by the user is liable to lead to non-compliance with the regulations, or even to put into doubt the EMC (ElectroMagnetic Compatibility) performance and the safety of the product. The manufacturer declines any responsibility for such operations.

*The performance and the operational safety of this product is guaranteed provided that it is used in normal operating parameters defined in this manual.  
Any modification of the pump not improved by the manufacturer can compromise the protection ensured by the pump.*

- The EMC performance of the product is obtained on the condition that the installation complies with the EMC rules. In particular, in disturbed environments, it is essential to:

- use shielded cables and connections for interfaces,
- stabilize the power supply line with meshing from the power supply source to a distance of 3m from the pump inlet.



*When switching off an item of equipment containing capacitors loaded with over 60 VDC or 25 VAC, take precautions at the access to the connector pins (single-phase motors, fitting with mains filter, frequency converter, monitoring system, etc.).*

## Electrical connections

### Rear panel of the pump

- In accordance with recommendations of EN 61010-1+ A2, the following warning symbol is on the variator inside the pump.



**Warning: risk of electrical shock.**

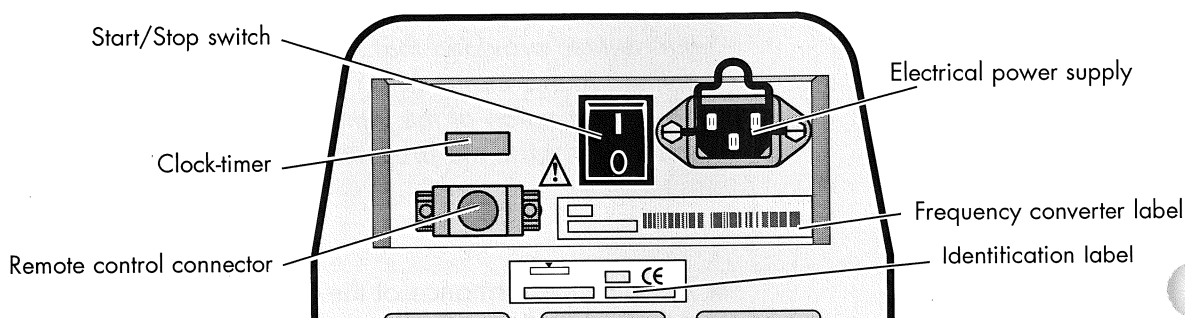

- Electrical motor is in accordance with CE standards offers the following voltage range:

Model	Voltage range		
ACP 15	110 V / 230 V 50/60 Hz	10 A / 5 A	1150 VA
ACP 28 / 40			

- The motor is equipped with an electrical frequency converter which allows automatically low or high voltage pump running, according to range voltage 110 V to 230 V, 50/60 Hz.

- The pump supplying cable is provided with the pump delivered. The earthing of the pump (frequency converter, covers, body of the pump) is realized by the cable connected with the network customer. The network customer should have himself a connection in the ground.

### Circuit breaker

- An 8 A circuit breaker is recommended for high voltage, 230 VAC + 10 %.
- A 12 A circuit breaker is recommended for low voltage, 110 VAC + 10 %.

***The pump is equipped with thermal sensors which stops pump starting-up depending on the temperature (see C 10).***

## Remote control connector wiring

■ In accordance with advice of EN 61010-1+ A2, the following warning symbol is near the remote control connector.



**Warning: refer to attached documents.**

### Remote control principle

The pump can be used in remote mode using the "Sub-D" connector at the rear of the pump.

Used by means of dry contacts:

- The remote control of the "Start / Stop" function (S1).

S1 = 0 → Stop      S1 = 1 → Start.

- Rotation speed remote control according to the table below:  
(O = open, 1 = closed):

ACP 15 Model				
S3	S4	S5	Rotation speed	
Contact status	Contact status	Contact status	Hz	rpm
S3 = 1	S4 = 0	S5 = 1	60	3 600
S3 = 1	S4 = 0	S5 = 0	70	4 200
S3 = 0	S4 = 1	S5 = 1	80	4 800
S3 = 0	S4 = 1	S5 = 0	90	5 400
S3 = 0	S4 = 0	S5 = 1	95	5 700
S3 = 0	S4 = 0	S5 = 0	100	6 000

DB 15 pins, male connector

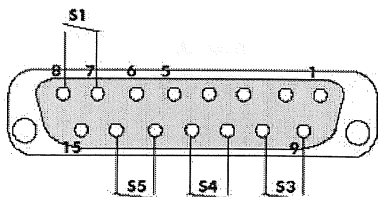

ACP 28 - ACP 40 Model				
S3	S4	S5	Rotation speed	
Contact status	Contact status	Contact status	Hz	rpm
S3 = 1	S4 = 1	S5 = 0	42	2 500
S3 = 1	S4 = 0	S5 = 0	50	3 000
S3 = 0	S4 = 1	S5 = 0	65	3 900
S3 = 0	S4 = 0	S5 = 0	80	4 800



**For pumps safety, do not exceed the maximum frequency:**  
 → 100 Hz for ACP 15 models,  
 → 80 Hz for ACP 28/40 models.

Note: Changing the rotational speed will affect the pumping speed and the ultimate pressure (see pumping curves).



## Remote control connector wiring

### Wiring of the remote control plug

S1, S3, S4 and S5 are inputs.  
S2 is an output (open collector).

**S1:** start/stop

**S2 closed:**  
pump at speed

**S3, S4, S5:**  
rotational speed selection

Pin 8, 10, 12 and 14 are connected to the ground of the control unit.

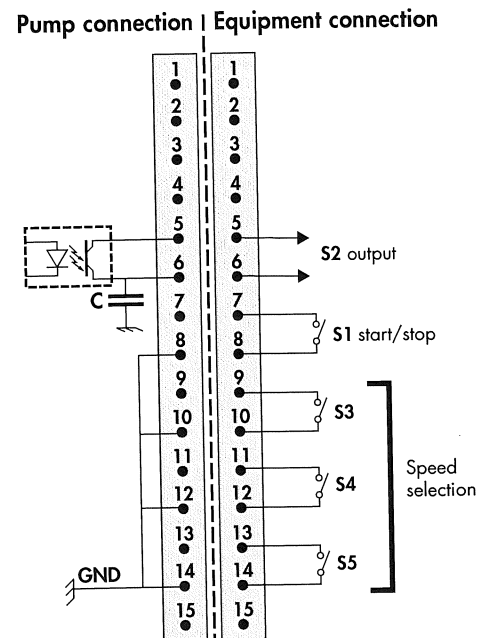

**Do not add any strap except S1, S3, S4 and S5.**



#### Output S2:

**Do not connect a relay between the pins 5 and 6.**  
The relay coil induces a current which may result in damage of the control unit.

**Wiring of output S2:**  
The maximum value of the current in the output must be of 35 mA.

### Wiring of output S2

S2 is an open collector output and must be wired as shown below.

V<sub>cc</sub> is a direct voltage (between 7 and 30VDC) supplied by the user. The value of the resistance R depends on the customer installation.

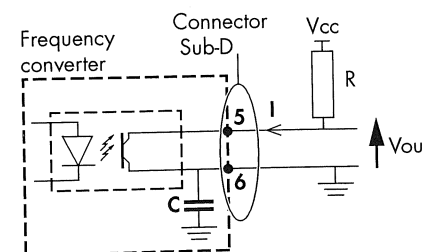

## Remote control connector wiring



**V<sub>cc</sub> and R values must be calculated so as not to exceed a current value of 35 mA.**  
Higher current will damage the frequency converter.

When the nominal speed is reached, the transistor becomes conductive («on-state») and V<sub>out</sub> = 0 V.

As long as the nominal speed is not reached, the transistor is blocked («off-state») and V<sub>out</sub> = V<sub>cc</sub>.



**This circuit can not be used for power transfer. For switching of power circuits an amplification stage is required.**

### Inert gas purge connection (G version)

#### Gas line connection

- For optimum performances -ball bearing protection-, the nitrogen supply should have the following characteristics:
  - Maximum moisture rate: 5 ppm of water
  - Dust < 1µm
  - Oil < 0.1 ppm
  - Pressure: 1.5 bar absolute (before the gas pressure reducing valve, customer supply)

■ Connect the gas line supply to the R 1/4 connector provides on purpose with flexible or stainless steel pipe (customer supply).

Note : we recommend to install an isolation valve on the gas supply line, nearest the inlet gas port to allow pump performance recovering when the gas line is not used (see **A 40, A 41**).

■ For optimum ball bearing protection, the neutral gas pressure must be set to 0.3 bar (relative pressure) according to the flowrate value given in the table below:

#### Nitrogen flowrate adjustment

	ACP 15	ACP 28/40
Flowrate max (slm)	5	1.65
Ultimate pressure (mbar)	$3 \times 10^{-1}$	$1 \times 10^{-1}$

e.g: ACP 28 G

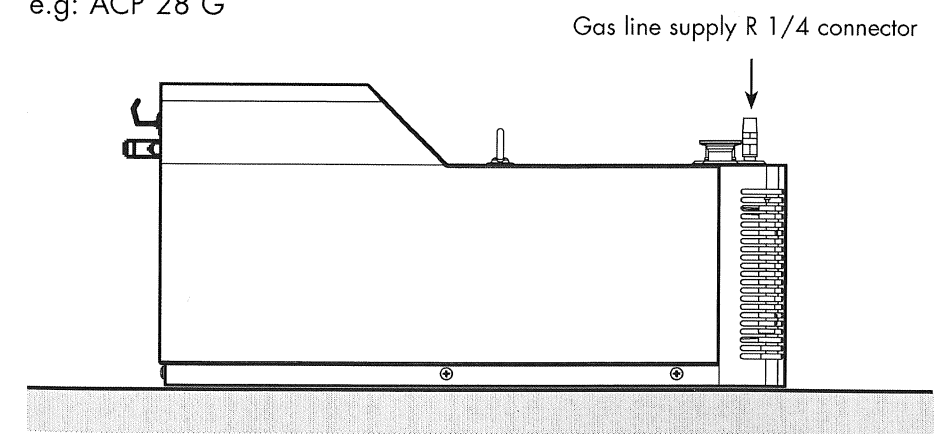

www.acepump.com

## Pump operation



CAUTION

*The ACP Series uses a specific gear oil. The amount required for pump operation is set at in the factory. Do not modify this oil level.*

### Pump temperature for start-up condition

*The pump is equipped with thermal sensors. When switching on the pump, if the temperature is:*

- less than 12 °C,
- or over than 40 °C,

*the pump doesn't start, but the fan is energized. The pump will start automatically when the ambient temperature is back in the authorized temperature range.*

### Operation in local mode

*In local mode, the pump can run only if the cover plug (delivered with the pump) is fitted on the remote control connector.*

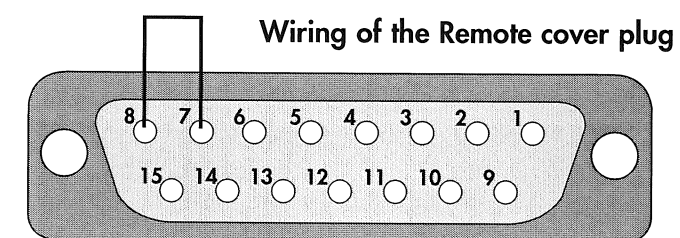

DB 15 pins, male connector (soldered side view). Factory wired with appropriate jumper for local operation.

### Remote mode

The pump can be used in remote mode only if the "Remote" control plug is wired according to the instructions (see **B 40**).

### Pump start-up

Pump is equipped with a main power switch. The pump starts up when the power line cord is connected, and main switch is on "1" position.

A time counter displays the pump running time in hour.

## Pump operation



**Avoid sudden changes in ambient temperature when the pump is running.**

### Pumping of condensable vapours

In order to better handle condensable vapours, it is necessary to pump with a hot pump. It is recommended to isolate the pump from the installation and let the pump run for at least 1 hour. Then open the isolation valve, the pump will operate in optimized conditions, thus reducing the risk of condensation inside the pumping module.

#### ACP 15 model

The ACP 15 pump features a gas ballast valve, the warm-up must be done with opening the gas ballast valve. Before switching off, isolate the pump from the installation and let it run for 1 hour with gas ballast opened.

### Operation of gas ballast (ACP 15 model)

Knob screwed: gas ballast closed,  
Knob unscrewed: gas ballast opened.

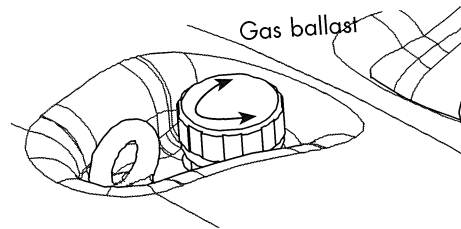

### Pump stop

Put the main switch on "0" position or press the circuit breaker of the customer's installation.

When the pump is remote controlled, the pump will be stopped by opening the "Start/Stop" contact (see B 40).

## Maintenance schedule

MODEL	TIMING (EVERY...)	DESCRIPTION
ACP 15	20 000 h or 4 years	Complete maintenance:
ACP 28 ACP 40	22 000 h or 4 years	<ul style="list-style-type: none"> <li>• oil draining</li> <li>• LP and HP bearing replacement</li> <li>• seal replacement</li> </ul>

M

Call customer Service\*

\* The manufacturer Center Service adress list at the back of the cover Manual.

Maintenance frequencies are typical values for non corrosive applications. For applications using G pump versions, these values can be reduced. Contact us.

M Performed by the manufacturer

## Instructions for cleaning

- The outside covers of the pump can be clean with a fluffy free duster. Use a cleaning product avoiding to damage the cover paint and stickers.

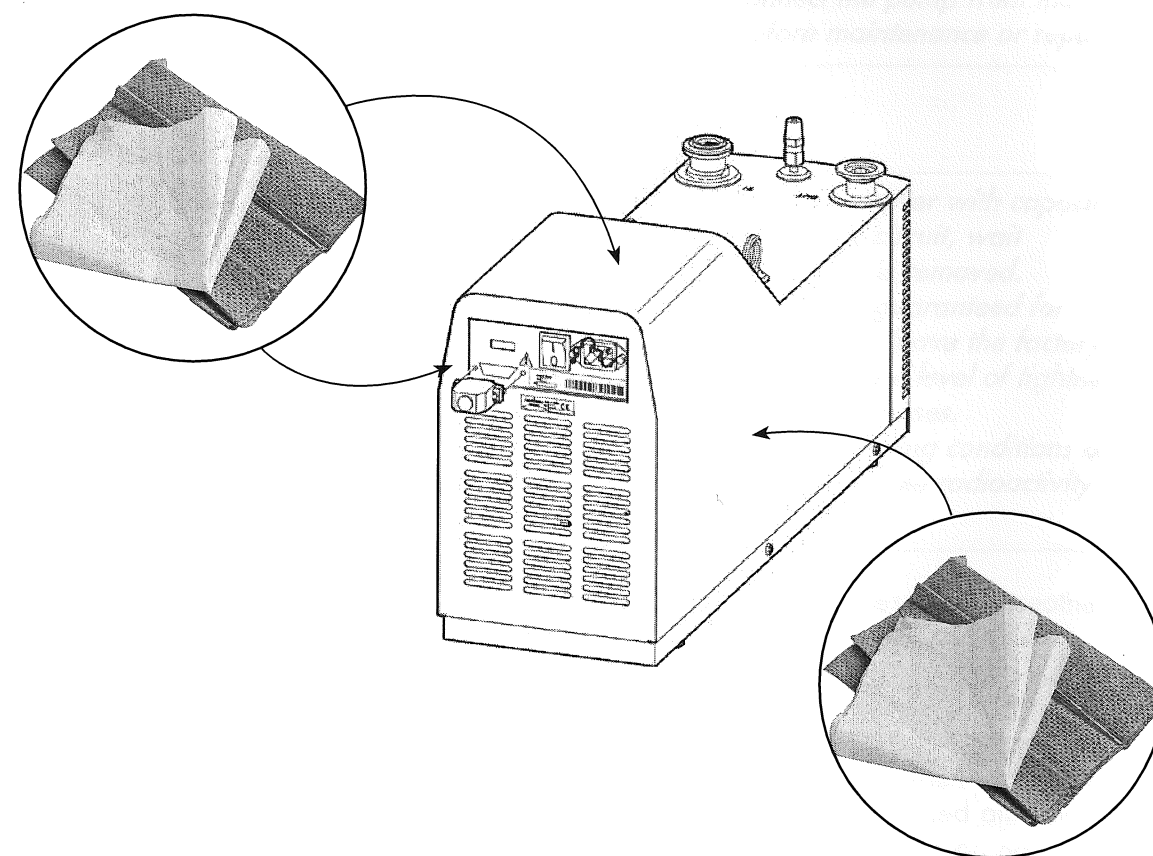

## Maintenance safety instructions

■ The maintenance or the repairing of the pump must only be done by a technician trained by the manufacturer. Center Service address list at the last cover page.



*Before any maintenance operation performed by a technician who has not received safety training (EMC, electrical safety, chemical pollution, etc.), disconnect the pump from main power and nitrogen source before maintenance or repair.*



- *The pump contains a frequency converter with capacitors. Before any intervention on the electric circuit, wait approximately 3 minutes, after power is removed.*
- *The leak tightness of the products is guaranteed for normal operating conditions when they leave the factory. It is the user's responsibility to maintain the level of tightness particularly when pumping dangerous gases.*
- *Before any operation, check the pumping conditions of the installation: toxicity, corrosion, possible radioactivity of pumped gases.*

- To wear gloves, protective glasses and, if necessary, a breathing mask.
- To ventilate the premises well.
- Not to dispose of residue but, if necessary, to have it destroyed by a qualified organization.
- Certain gases can become corrosive and toxic when trapped in oil. Always wear protective gloves when handling used and dirty pump gear oil, drain it into a closable container, and do not breathe the fumes of the oil. Always use a fully self-contained breathing apparatus.
- Always dispose of used dirty oil, or sub-products properly and in compliance with all local, state and federal environmental laws and regulations.

*After a maintenance operation on the pump or on the installation, it is necessary to perform a helium leak-tightness test. The manufacturer can provide specific training to know the tightness test method and supply helium leak detectors. Contact us.*

**Procedure for returning vacuum pumps**

**No contaminated pump**

- Close the inlet and exhaust pipe with black plastique cap, supply with the pump.

For a best analysis failure of your pump, it is recommended to fill in and send to the Customer Service:

- Safety Questionnaire (see model in **G 30**),
- Analysis Questionnaire (see model in **G 40**).

**Contaminated pump**

- Close the inlet and exhaust pipe of the pump with the following connecting accessories (available in manufacturer's catalog):

Accessories	DN 16 ISO-KF	DN 25 ISO-KF	DN 40 ISO-KF
Centering ring with O-ring	068 193	068 189	068 194
Stainless steel blank flange	068 195	068 196	068 197
Clamp	083 333	083 264	087 163

For a best analysis failure of your pump, it is recommended to fill in and send to the Customer Service:

- Safety Questionnaire (see model in **G 30**),
- Analysis Questionnaire (see model in **G 40**).



*Remaining process gases in the pump may cause severe injury or death.  
Before removing the pump, keep N2 flow during 15 minutes (G version).  
Nitrogen pressure at the inlet gas pipe, must be around 300 mbar (relative).*



*During pump removal, operator could be in contact with process residues on the exhaust which could cause severe injury or death.  
Ask your safety department for instructions according to the local statements.*

### ACP 15 / 15 G pumping curves

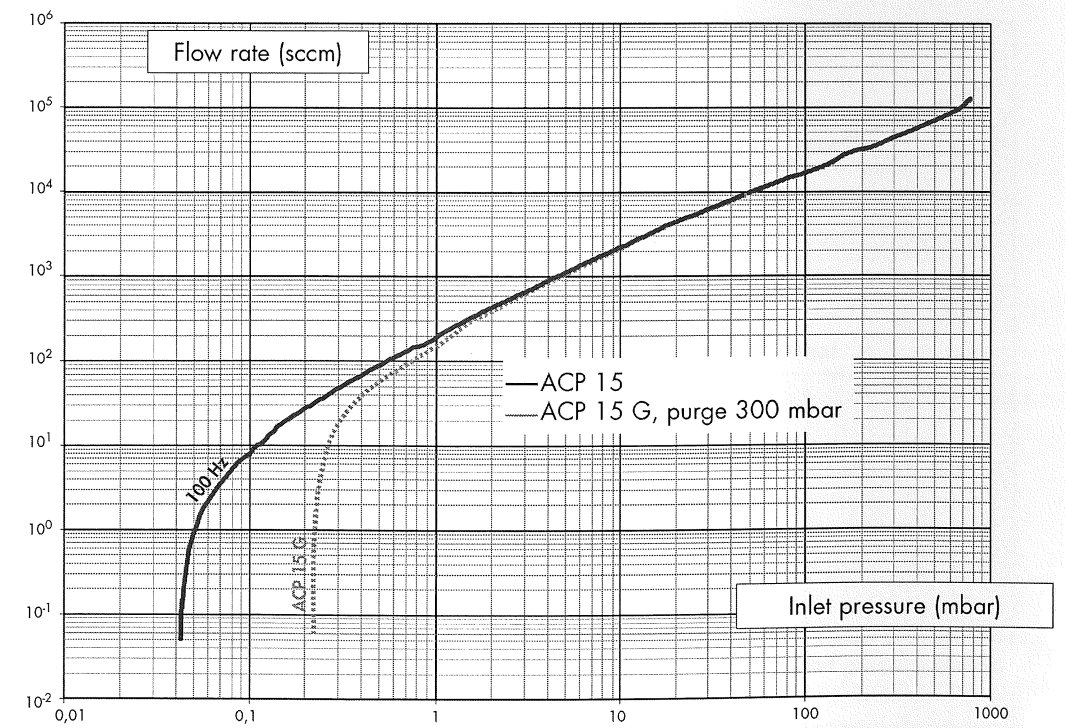
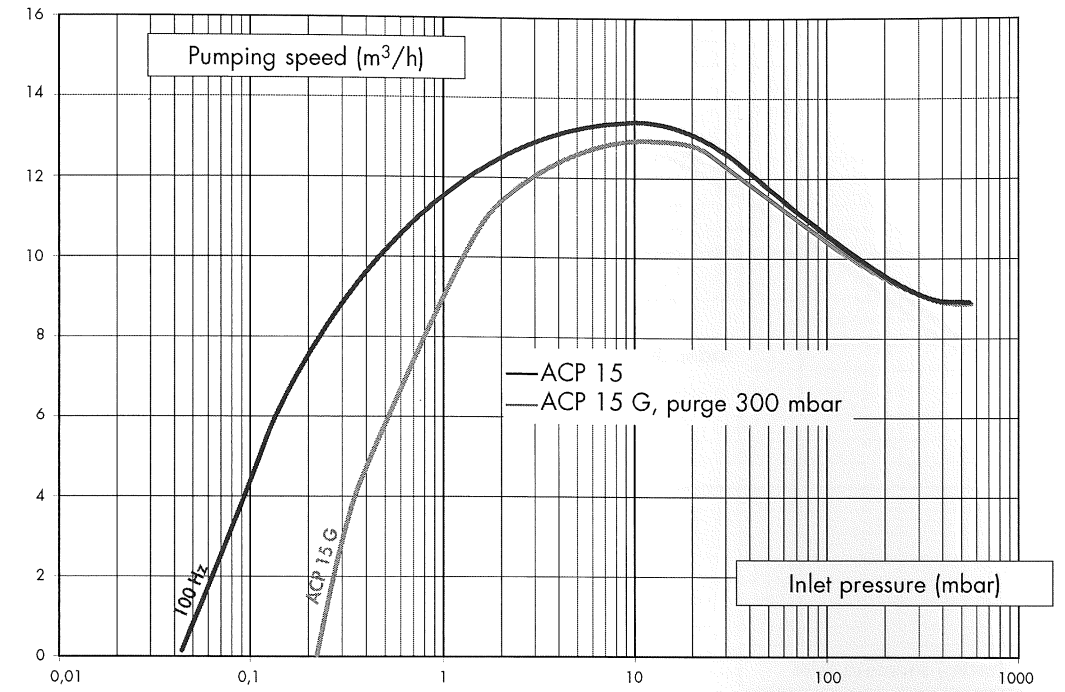



### ACP 28 / 28 G pumping curves

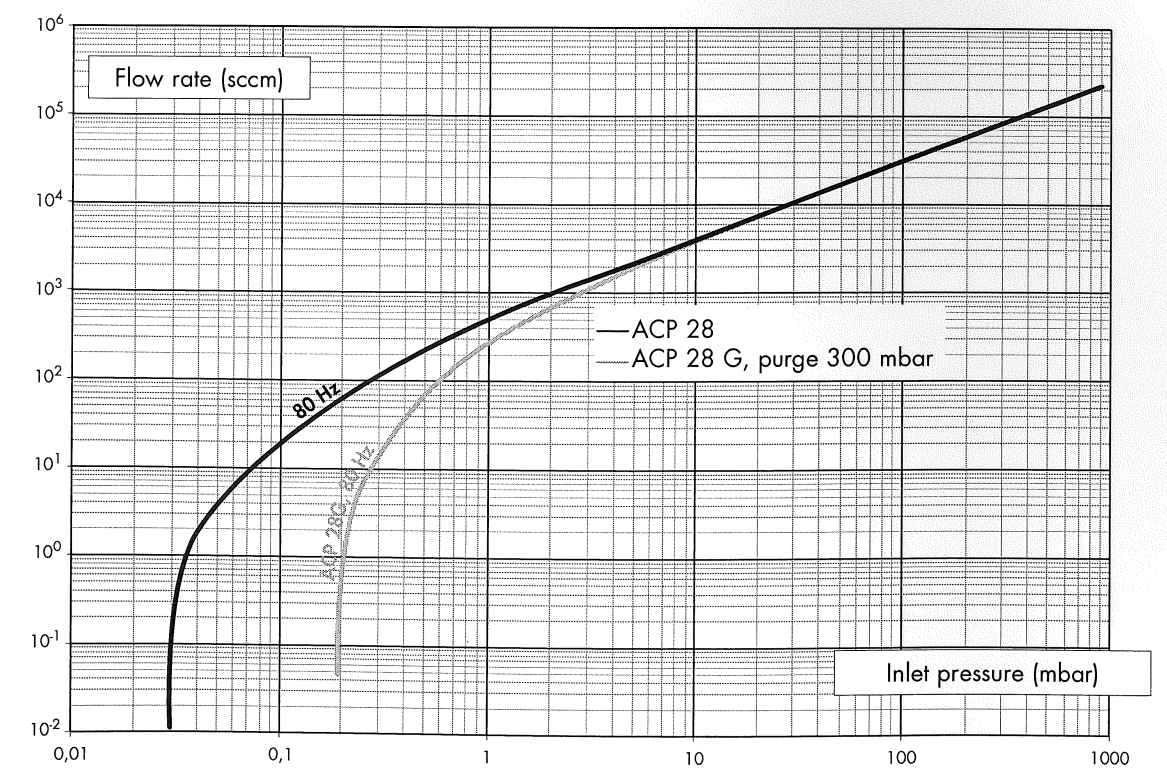
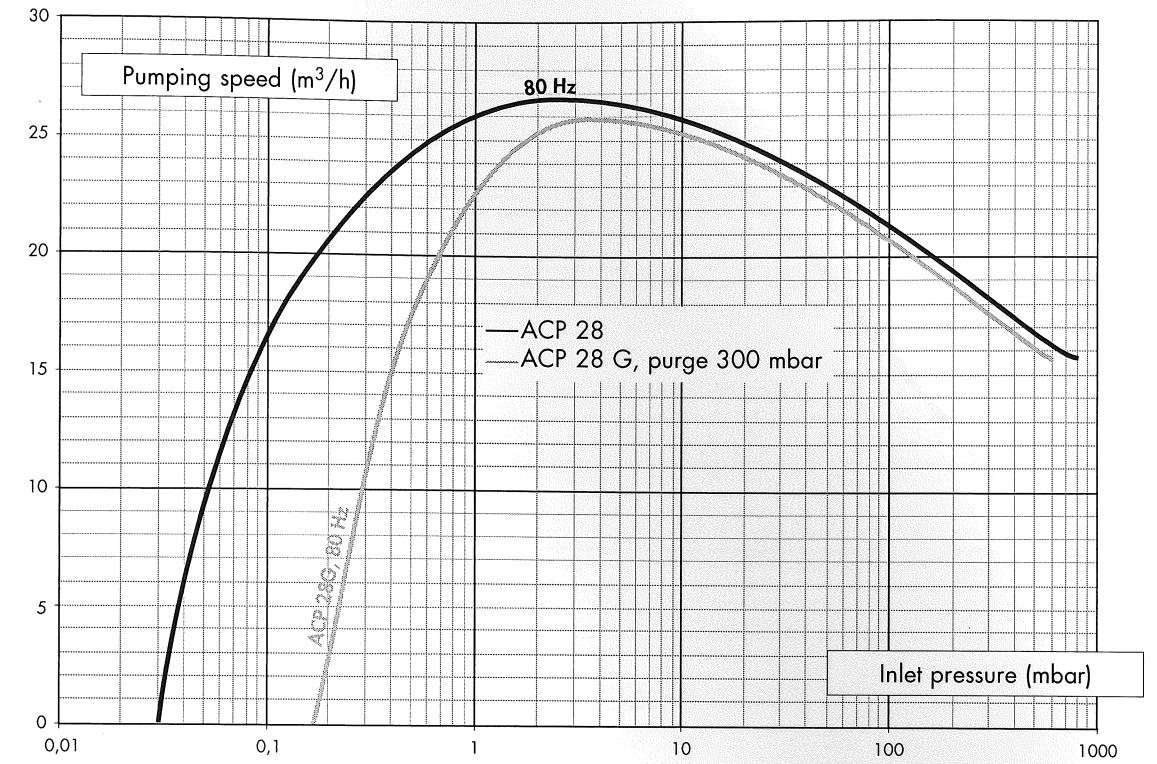

ALCATEL

## SAFETY QUESTIONNAIRE

### Procedure for returning ALCATEL vacuum pumps and helium leak detectors

You wish to return an Alcatel vacuum pump or helium leak detector for maintenance. The equipment will be dismantled and possibly cleaned by a technician from our Service Centre. In order to ensure the effective safety of our staff and protection of the environment, we need to know the types of gas or substances with which the pump or leak detector has been used. This will enable us to take the appropriate safety measures.

The following page contains a questionnaire that you can use for this purpose. This procedure complies with the European Community's L360 directives and articles L231 and R231 of the French Labour Code.

We wish to draw your attention to the following points:

- The risk may be of the following nature:
  - **Chemical:** danger to health, risks of explosion, fire, risks for the environment. Please indicate the chemical formula and name of the gases or substances that have been in contact with the equipment (pump or helium detector).
  - **Biological:** pathogenic germs, micro-organisms (bacteria, viruses, etc.) classes 1 to 4 and group E. We are currently unable to deal with contamination of this sort without risk to the safety of our staff. If your equipment has been contaminated in this way, contact us so that we can try to find a solution together.
  - **Radioactive:** contact us in this case.

- **Attention!**

In the event of chemical contamination, please indicate the following gases or substances:

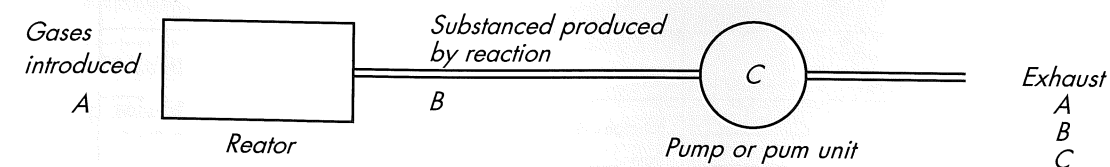

- gases (or substances) introduced into the reactor and which may be found at the exhaust (A),
  - gases (or substances) resulting from the reaction or process (B),
  - gases (or substances) that may possibly be formed inside the pump (due to a thermodynamic or chemical reaction, condensation, deposition, precipitation, etc.) (C)
- Precautions need to be taken before transferring contaminated pumps. Please contact customer service for recommendations.



**QUESTIONNAIRE DE SECURITE  
SAFETY QUESTIONNAIRE**

**Procédure de retour des Pompes à Vides et Détecteur de Fuite à Hélium ALCATEL  
Procedure for returning ALCATEL Vacuum Pumps and Helium Leak Detectors**

(Ce formulaire ne peut être rempli et signé que par une personne habilitée)  
(This questionnaire is only to be filled in and signed by an authorized person)

<b>SOCIETE - COMPANY</b> Nom Société - Name of company : _____ Nom personne - Name of person : _____ <small>(Qui remplit ce formulaire) - (Who has filled in questionnaire)</small> Fonction - Position : _____ N Tél. - Tel. no : _____ N Fax - fax no : _____ <small>(Pour renseignements éventuels sur les produits utilisés) - (for any information on products used)</small>		<b>EQUIPEMENT - EQUIPEMENT</b> Description : _____ _____ N de Série - Serial no : _____ Type de procédé - type of process : _____ <small>(Pour lequel l'équipement est utilisé) - (for which equipment is used)</small> Date de l'expédition - Date of consignment : _____	
<b>INTERVENTION - SERVICE</b> Intervention souhaitée (Révision, réparation, ...) - Service required (overhaul, repair, etc.): Type d'anomalie constatée - Type of anomaly observed : _____			
<b>PROCEDE CUIVRE - COPPER PROCESS</b> Produit utilisé sur un procédé Cuivre - Product used on a Copper process Oui - Yes Non - No Si "Oui" emballage étanche et étiquette spécifique sont requis - If "Yes", sealed package and specific label are required			
<b>ASPECT SECURITE - SAFETY ASPECT</b> L'équipement mentionné ci-dessus a été en contact avec les produits suivants - The above equipment has been in contact with the following substances : (nom et formule chimique) - (name and chemical formula)			
Ces produits présentent un risque de nature <i>These substances present the following risks</i>			
<b>Chimique - Chemical</b> Toxique - Toxic                      Oui - Yes                      Non - No Carcinogénique - Carcinogenic    Oui - Yes                      Non - No Combustible - Combustible          Oui - Yes                      Non - No Corrosive - Corrosive                Oui - Yes                      Non - No Explosive - Explosive                Oui - Yes                      Non - No Biologique - Biological              Oui - Yes                      Non - No Radioactive - Radioactive          Oui - Yes                      Non - No Autre - Other <small>(Vous reporter éventuellement à la page précédente) - (See preceding page if necessary)</small>		Explication détaillée - Detailed explanation Si "Oui" risque de nature - If "Yes", what type of risk _____ _____ _____ _____ _____	
<b>SIGNATURE</b> Vous avez répondu "Oui" à une des questions précédentes : Je confirme que seules les substances précisées ont été en contact avec l'équipement sus-mentionné, et que les procédures de préparation, d'emballage, et de transport ont été respectées.  You have replied "yes" to one of the above questions: I confirm that only the substances mentioned have been in contact with the above equipment and that the preparation, packing and transport procedures have been complied with.		Je confirme que le matériel sus-mentionné n'a été en contact avec aucune substance dangereuse, et a été vidé de son huile. (Si applicable)  I confirm that the above equipment has not been in contact with any dangerous substance and has been emptied of oil. (if applicable)	
Réponse "Oui" (nécessite une protection) Reply "Yes" (requires protection)		Réponse "Non" (sans risque) Reply "No" (no risk)	
Nom - Name : _____ Fonction - Position : _____ Date : _____ Signature autorisée - Authorised signature : _____		Fonction - Position : _____ Date : _____ Signature autorisée - Authorised signature : _____	
Tampon / Cachet Stamp / Seal		Tampon / Cachet Stamp / Seal	

**ACP 15 / 15 G / ACP 28 / 28 G / ACP 40 / 40 G  
ANALYSIS QUESTIONNAIRE**

INSTALLATION DESCRIPTION / CONDITION USE		
<b>CUSTOMER:</b>	<b>SERIAL NUMBER:</b>	
<b>Type of the pump:</b>	<input type="checkbox"/> Model ACP 15 <input type="checkbox"/> Model ACP 28 <input type="checkbox"/> Model ACP 40	<input type="checkbox"/> Model ACP 15 G <input type="checkbox"/> Model ACP 28 G <input type="checkbox"/> Model ACP 40 G
<b>Pump installed since:</b>	<input type="checkbox"/> Less than 3 months <input type="checkbox"/> Between 6 months and 1 year	<input type="checkbox"/> Between 3 and 6 months <input type="checkbox"/> More than 1 year
<b>RUNNING TIME</b>		
<b>Total running time:</b>	..... hours	
<b>Frequency of use:</b>	<input type="checkbox"/> Non-stop <input type="checkbox"/> Between 8 and 12 hours/year <input type="checkbox"/> Less than 1 hour/day	<input type="checkbox"/> Between 12 and 24 hours/day <input type="checkbox"/> Between 1 and 8 hours/day <input type="checkbox"/> A few hours/week
<b>Using voltage:</b>	<input type="checkbox"/> 220 V <input type="checkbox"/> 115 V	<input type="checkbox"/> Other:
<b>Environment:</b>	<input type="checkbox"/> R&D <input type="checkbox"/> Basement	<input type="checkbox"/> Cleanroom <input type="checkbox"/> Other:
<b>Functioning ambient temperature:</b>	<input type="checkbox"/> Less than 10 °C <input type="checkbox"/> From 20 to 30 °C <input type="checkbox"/> More than 40 °C	<input type="checkbox"/> From 10 to 20 °C <input type="checkbox"/> From 30 to 40 °C
<b>Pumped volume:</b>	<input type="checkbox"/> Less than 10 l <input type="checkbox"/> Between 50 to 100 l	<input type="checkbox"/> Between 10 and 50 l <input type="checkbox"/> More than 100 l
<b>Nature of pumped gases:</b>	.....	
<b>Application/Equipment:</b>	.....	

SEIZURE ANALYSIS		
<b>DATE OF FAILURE:</b>	.....	
<b>The pump seized:</b>	<input type="checkbox"/> at first start <input type="checkbox"/> on re-start after complete stop <input type="checkbox"/> on re-start of new cycle after stand-by	<input type="checkbox"/> during normal cycle <input type="checkbox"/> During stand-by mode
<b>Place of storage:</b>	<input type="checkbox"/> stored at the place of use <input type="checkbox"/> is often changed of site	<input type="checkbox"/> stored in another room temperature: .....
<b>Particular handling conditions:</b>	.....	
<b>Free comments:</b>	.....	

F 00956 - Edition 02 - Juin 03

GB 00957 - Edition 04 - March 06

## DECLARATION OF CONFORMITY

We, Alcatel Vacuum Technology France  
98, Avenue de Brogny, BP 2069  
74009 ANNECY France

## ISO 9001 CERTIFIED

declare under our sole responsibility that the following products :

**ACP 15**  
**ACP 15G**

to which this declaration relates are in conformity with the following European Directives

73 / 023 / EEC	Low Voltage Directive
89 / 336 / EEC	Electromagnetic Compatibility Directive
93 / 68 / EEC	Council Directive (EC Marking)
98 / 37 / EEC	Machinery Directive

The standards, normative documents, and/or specifications to which the products comply are

ENV 50204	Immunity to radiated electromagnetic field from digital radio telephones
NF EN 55011 class A	EMC / Radio disturbance characteristics
NF EN 61000-3-2	EMC / Harmonic current emissions
NF EN 61000-3-3	EMC / Limitation of voltage changes in public low-voltage supply
NF EN 61000-4-2	EMC / Immunity to electrostatic discharge
NF EN 61000-4-3	EMC / Immunity to radiated, radio-frequency, electromagnetic field
NF EN 61000-4-4	EMC / Immunity to electrical fast transient / burst
NF EN 61000-4-5	EMC / Immunity to surge
NF EN 61000-4-6	EMC / Immunity to conducted disturbances, inducted by radio-frequency fields
NF EN 61000-4-11	EMC / Immunity to short interruptions and voltage variations
NF EN 61000-6-2	EMC / Generic immunity standard - Industrial environments
NF EN 61000-6-4	EMC / Generic emission standard / Industrial environment
NF EN 61010-1	Safety requirements for electrical equipment for measurement, control and laboratory use
NF EN 1012-2	Safety requirements for vacuum pumps
NF EN 563	Safety of machinery - Temperatures of touchable surfaces
UL 3101-1	General requirements - Electrical equipment for laboratory use
CSA-C22.2 No 1010.1-92	Safety requirements for electrical equipment for measurement, control and Laboratory use

Mr J.Y. GUEGAN, Président Directeur Général

Annecy, 20/01/06

## DECLARATION OF CONFORMITY

We, Alcatel Vacuum Technology France  
98, Avenue de Brogny, BP 2069  
74009 ANNECY FRANCE

## ISO 9001 CERTIFIED

declare under our sole responsibility that the following products :

ACP 28 / ACP 28 G  
ACP 40 / ACP 40 G

to which this declaration relates are in conformity with the following European Directives

73 / 023 / EEC	Low Voltage Directive
89 / 336 / EEC	Electromagnetic Compatibility Directive
93 / 68 / EEC	Council Directive (E.C Marking)
98 / 37 / EEC	Machinery Directive

The standards, normative documents, and/or specifications to which the products comply are

NF EN 50081-1	EMC / Generic emission standard / Light industry
NF EN 50081-2	EMC / Generic emission standard / Industrial environment
NF EN 50082-1	EMC / Generic emission standard / Light industry
NF EN 50082-2	EMC / Generic immunity standard / Industrial environment
ENV 50204	Radiated electromagnetic field from digital radio telephones - Immunity test.
NF EN 55011 A1 c1B	EMC / Limits for Electromagnetical Conducted and Radiated Interferences
NF EN 55022 c1B	EMC / Limits for Electromagnetical Conducted and Radiated Interferences
NF EN 61000-3-2	EMC / Harmonic current emissions
NF EN 61000-4-2	EMC / Immunity to Electrostatic Discharges
NF EN 61000-4-3	Standard Immunity to Radiated Electromagnetic fields
NF EN 61000-4-4	EMC / Immunity to Transient Burst
NF EN 61000-4-5	EMC / Immunity to shock waves
NF EN 61000-4-6	standard Immunity to conducted disturbances induced by radio frequency fields
NF EN 61000-4-11	EMC / For mains power cuts
NF EN 61010-1 +A2	Safety of Machinery / Electrical Equipment of Machinery Safety requirements for electrical equipment for measurement, Control and laboratory use
NF EN 61000-6-2	Electromagnetic Compatibility (EMC) - Part 6-2: Generic standards - Immunity for industrial environments
NF EN 1012-2	Compressors and vacuum pumps - Safety requirements
NF EN 563	Safety of machinery - Temperatures of touchable surfaces
NF EN 60742	Transformer design

Mr J.Y. GUEGAN, Président Directeur Général

Annecy, 05/04/04

## SAFETY INSTRUCTIONS CONCERNING PRODUCT INSTALLATION, OPERATION AND MAINTENANCE

Our ALCATEL products are designed and tested to provide maximum safety. However, in order to obtain the best level of safety, the following must be observed:

- the user manual during product transport, installation, operation and maintenance.
- the safety instructions below.

■ Our products are designed to comply with current EEC regulations. **Any modification of the product made by the user** is liable to lead to non-compliance with the regulations, or even to put into doubt the EMC (electromagnetic compatibility) performance and the safety of the product. ALCATEL declines any responsibility for such operations.

■ Before any maintenance operations on a product performed by a maintenance technician who has not received safety training (EMC, electrical safety, chemical pollution, etc.), isolate the product from the various energy sources (electricity, compressed air, etc.).

■ When switching off an item of equipment containing capacitors loaded with over 60 VDC or 25 VAC, take precautions at the access to the connector pins (single-phase motors, fitting with mains filter, frequency converter, monitoring system, etc.).

■ Equipment storage: our equipment can be stored without particular storage precautions for 3 months (ambient temperature between 5 and 40°C). After this period, factors such as the degree of humidity, temperature, saline atmosphere, etc. may cause the damage of certain «sensitive» elements (elastomers, lubricants, etc.). It is recommended to refer to the specific storage conditions for each item of equipment listed in the user manual.

■ For all equipment handling, use the devices provided for this purpose (lifting rings, handle, etc.).

■ The performance and the operational safety of this product are guaranteed provided that it is used in normal operating conditions.

■ The vacuum pump is also a compressor: incorrect use may be dangerous. Study the user manual before commissioning the pump.

■ Remove the guards blocking the intake and exhaust (and, if applicable, purge) holes; these components prevent foreign bodies from entering the pump during transport and storage. **It is dangerous to leave them on the pump in operation.**

■ Make sure that the parts or containments connected to the intake of our pumps withstand a negative pressure of 1 bar with reference to the atmospheric pressure.

■ For machines which use lubricants, it is recommended to request the manufacturer for the safety data sheets concerning the product used.

■ Our pumps are tested in the factory with ALCATEL oil. It is recommended to use the same oil in operation.

■ Whenever changing the type of oil, refer to the user manual for the procedure and the type of lubricant tolerated.

■ When pumping oxygen-charged gases, mineral oil must not be used above 30% oxygen in the pumped gases: use synthetic or inert oils.

■ **In addition, it is not recommended to use fluids such as tri-aryl-phosphate-ester.**

■ It is recommended to connect the pump exhaust to a flue gas evacuation pipe.

■ At the pump exhaust, the evacuation circuit must be such that the lowest possible resulting excess pressure in the vessel: an excess pressure of 0.3 bar is a maximum for correct pump operation.

■ The machines are designed so as to prevent any thermal risk to the user's safety. However, specific operating conditions may generate temperatures justifying particular attention on the part of the user (external surfaces > 70°C).

■ Product tightness is guaranteed upon leaving the factory for normal operating conditions. It is the responsibility of the user to ensure that the level of tightness is maintained when pumping dangerous gases.

■ After a complete maintenance operation, it is recommended to perform a tightness test with helium.

■ Before any maintenance operation, check the installation's pumping conditions: toxicity, corrosion, any radioactivity of the pumped gases. Depending on the case, we recommend:

- to purge the pumping installation with dry nitrogen before any intervention;
- to wear gloves, protective goggles and a breathing mask, if necessary;
- to air the room well and disassemble the equipment under a suction hood;
- not to discharge used oils and residues in the usual system and, if necessary, to have them destroyed by a competent organisation.