

Quick Start Guide

Sensor Cartridge Installation



mda scientific

1. Introduction

The MIDAS® sensor cartridge is supplied separately and needs to be fitted to the detector's main chassis. Before installing a sensor cartridge check that the number on the sensor cartridge label matches the gas type and range for the function required. All sensor cartridges are supplied calibrated.

Some MIDAS® sensor cartridges are capable of monitoring for more than one type of gas. For details of how to set the different gas types for a multi gas sensor cartridge refer to the MIDAS® operating manual MIDAS-A-001.

NOTE: To avoid potential contamination of the gas sensing surface, avoid handling the sensor cone. Hold sensor cartridge by the locking tabs. Avoid exposure to dust, grease or any other chemical contaminants.

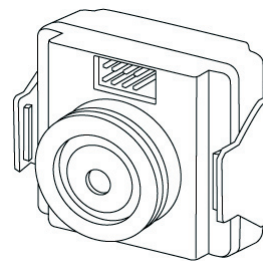
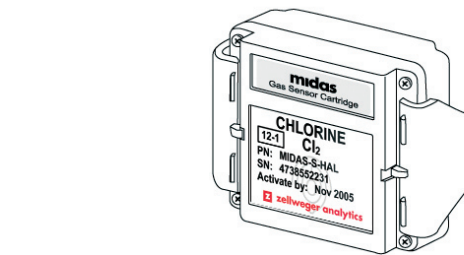

2. Sensor cartridge fitting/replacement

1. Unscrew the captive thumbscrew located on the front panel and remove the cover by pulling it forwards off the main chassis (see diagram 1). Switch power off using the power switch on the backplane of the unit.
2. Ensure the power switch on the terminal module is in the 'off' position.
3. Remove the old sensor cartridge from the unit (if fitted) by unclipping the two sensor cartridge locking tabs located either side of the sensor cartridge and using them to firmly pull the sensor cartridge out (see diagram 2).
4. Fit the new sensor cartridge by aligning the pins at the top of the sensor cartridge with the socket in the sensor cartridge chamber.
5. Carefully push the sensor cartridge into the sensor cartridge chamber until fully home and lock in place using the tabs either side of the sensor cartridge (see diagram 3).
6. Switch the power switch located on the terminal board to the 'on' position.
7. Refit the detector's cover by aligning the slots either side with the locating tabs on the mounting bracket assembly and pushing the cover horizontally until home.
8. Tighten the thumbscrew located on the front panel (see diagram 4).

2. Sensor cartridge fitting/replacement

Diagram 1.
Removing detector cover

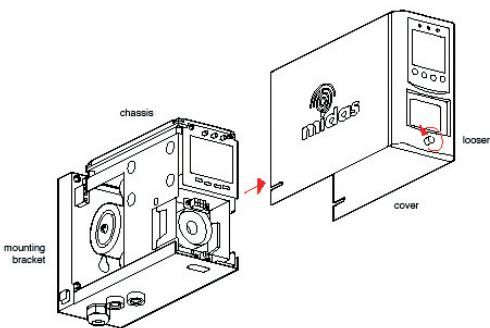

Diagram 2.
Removing sensor cartridge

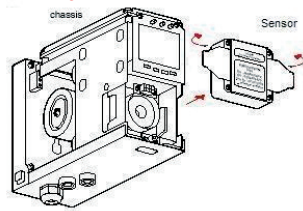

Diagram 3.
Fitting/replacing sensor cartridge

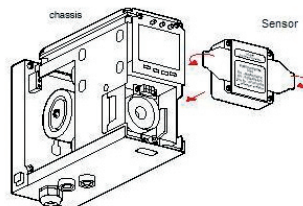
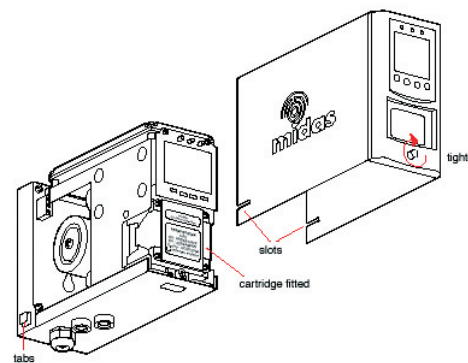

Diagram 4.
Refitting detector cover



For further details refer to the MIDAS® operating manual MIDAS-A-001.

Contact US

ZENTER AMERICAS
Zellweger Analytics Distribution, Inc.
400 Sawgrass Corporate Pkwy.
Suite 100
Sunrise, FL 33325
Tel: +1 954 514 2700
Toll free: +1 800 538 0363
Fax: +1 954 514 2784
sales@zelana.com

ZENTER EUROPE
Wilstrasse 11-U11
CH-8610 Uster
Switzerland
Tel: +41 (0)1 943 4300
Fax: +41 (0)1 943 4398
sales@zelana.co.uk

www.lumidor.com

www.zelana.com

zellweger analytics

PART No. MIDAS-A-021
Issue 1.1 02.05